

NEWTON COUNTY

WASTEWATER TREATMENT SYSTEMS MANUAL



**REVISED NEWTON COUNTY HEALTH DEPARTMENT
WASTEWATER TREATMENT SYSTEMS #95-6**

INTRODUCTION.....	3
SITE INFORMATION.....	4
ORDINANCE.....	5
DEFINITIONS.....	14
I. Wastewater Treatment System Procedure	
A. Application For Permit.....	18-19
1. Permits	
2. Projects Requiring Permits	
3. Permit Application Information	
4. Permit Fee Schedule	
5. Permit Application Review	
B. Construction.....	20
C. Permit Exceptions.....	21
1. Permit And Site Evaluation Expiration	
2. Special Use Permit	
3. Variance Request	
D. Installer Registration Revocation or Suspension.....	22
E. Responsibilities.....	23-24
1. Board Of Trustees	
2. Administrator	
3. Environmental Public Health Specialist (EPHS)	
4. Installer	
5. Homeowner	
6. Contractor	
7. Tank Cleaner	
8. Soil Scientists	
F. Administration Of Ordinance.....	25
1. Notice Of Non-Compliance	
2. Complaints	
3. Violations	
II. Design and Construction	
A. General.....	26
B. Site Evaluation.....	26
C. Minimum Set Back Distances.....	27
D. Flow Rates.....	29
E. Sinkholes.....	32
F. Building Sewers.....	33
G. Tanks.....	33
H. Absorption Systems.....	37
I. Advanced Systems.....	46

III. Soil Evaluation

A. General.....	47
B. Site Evaluation.....	47
C. Site Evaluation Classification.....	47
D. Topography And Landscape Position.....	47
E. Soil Characteristics (Morphology).....	48
F. Soil Drainage.....	51
G. Soil Thickness.....	52
H. Restrictive Horizons.....	52
I. Other Applicable Factors.....	52
J. Determination Of Overall Site Suitability Classification.....	52
K. Design Criteria.....	53

Appendix A. Forms

A. Permit Application Procedure.....	57
B. Permit To Install.....	58
C. Permit To Repair.....	59
D. Permit Renewal.....	60
E. Special Use Permit Request.....	61
F. Variance Request.....	62

Appendix B. Drawings

A. Curtain And Vertical Drains.....	64
B. Sand-Lined Trenches And Shallow Placement.....	65
C. Step-Down Systems.....	66
D. Level Systems And Trenches.....	67
E. Drop Box Systems.....	68

INTRODUCTION

Improper wastewater disposal and treatment is a water quality concern for homeowners across the nation. Inadequate site information, design, construction, and maintenance of wastewater treatment systems can result in water quality problems, nuisance conditions, and costly repairs to rehabilitate a failing system. Failing wastewater systems are not only those that we can see and smell, but those that do not surface to the top of the ground but fail to remove the disease-causing organisms before the effluent reaches our groundwater. Some of the common communicable diseases that can be transmitted by improperly treated human wastes are: Salmonellosis, Shigellosis, Giardiasis, Amebiasis, Infectious Hepatitis, Campylobacter, Clostridium, Tetanus, Diarrhea, Yersiniosis, Hookworm, Cholera, Hand-foot and mouth disease, Paratyphoid fever, Typhoid fever, Dysentery, Schistosomiasis, Poliomyelitis, and Staphylococcal.

Numerous studies done by the Missouri Department of Health during 1988-89 show that many wastewater treatment systems are failing.

The most common individual system, the septic tank-absorption, has a notorious reputation of failure. Because of inadequate siting, design, construction, and maintenance, many individual systems have, historically, been installed on sites that are not suitable for conventional soil absorption systems. Many advances in technology for proper installation for individual systems have been made since the 1980's.

Wastewater treatment systems have been plagued by poor public acceptance; feelings that those systems are second rate, temporary, or failure prone. That situation changed in the 1980's when wastewater treatment systems began gaining desired recognition as a viable wastewater management alternative that can provide excellent, reliable service at a reasonable cost, while still preserving environmental quality.

In this time of population movement to rural and semi-rural areas, the decline of federal and state construction grants for public wastewater treatment facilities and the high cost of privately owned centralized collection systems, we are faced with the need for more information and control of the planning process, design, construction, and management of wastewater treatment systems.

It is vital that the citizens of this county protect the natural resources that we are so fortunate to have at very little expense. In order to keep these resources available at a cost level that is not prohibitive for the average citizen of our county, we must protect them with all available measures.

The rules and regulations in this manual are designed to describe and define each step in this protection and are based on MO 19 CSR and the Missouri Clean Water Act.

In closing, the requirements are spelled out clearly. In a situation that is questionable, the health department has the responsibility to pursue what means are necessary to protect the health, safety and well being of the citizens of this county and their natural resources.

SITE INFORMATION

In general, systems designed to discharge partially treated wastewater to the soil for ultimate disposal, are the most reliable and least costly individual systems. This is because little pretreatment of the wastewater is necessary before application to the soil. The soil, by several different chemical and biochemical processes, can treat the wastewater to an acceptable quality for discharge into the groundwater under the proper conditions.

The site evaluation is to consider the characteristics of the area for their potential to treat and dispose of wastewater. A system design must consider the treatment of wastewater as high a priority as disposal. In the past, the typical approach was to make disposal the first and sometimes only priority as evidenced by the use of seepage pits and deep trenches.

To understand absorption field design requirements, it is absolutely essential that one understands the importance given to adequate treatment of the effluent before complete disposal.

One basic objective is to distribute the effluent over a wide enough area so as to not overload the soil's capacity for adequate treatment. Another basic objective in designing a system is to keep the trench depth as shallow as possible. One advantage of shallow trenches is to promote more evaporation and transpiration of excess water. The fundamental reason for keeping the absorption trenches close to the surface is to provide for better conditions for microbial activity and treatment of the effluent.

Revised Newton County
Wastewater Treatment Systems
Ordinance NO. 95-6

AN ORDINANCE GOVERNING THE CONSTRUCTION, MODIFICATION, INSTALLATION AND OPERATION OF WASTEWATER TREATMENT SYSTEMS WITHIN THE COUNTY, REQUIRING CERTAIN PERMITS AND QUALIFICATIONS, AND PROVIDING PENALTIES FOR VIOLATION THEREOF:

SECTION 1. AUTHORITY. This ordinance is enacted pursuant to Section 192.300, RSMo 1986, which provides, in part as follows: The county commissions and the county health center boards of the several counties may make and promulgate orders, ordinances, rules or regulations respectively, and will tend to enhance the public health and prevent the entrance of infectious, contagious, communicable or dangerous diseases into such a county, but any orders, ordinances, rules or regulations shall not be in conflict with any rules or regulations authorized and made by the department of health in accordance with this chapter or by the department of social services under Chapter 198 RSMo.

SECTION 2. APPLICABILITY. These regulations apply to all wastewater treatment systems of three thousand (3,000) gallons per day or less, except for wastewater treatment systems connected to the sewage system operated on behalf of an incorporated municipality or incorporated public sewer district within the county.

Any city ordinance pertaining to on-site wastewater treatment systems shall meet or exceed all requirements as set forth in this ordinance.

Any city without an on-site wastewater treatment system ordinance shall meet all the requirements of this ordinance.

SECTION 3. DEFINITIONS. The following words and phrases shall have the following meanings:

- 3.01 Board of Trustees: The Newton County Health Department Board of Trustees.
- 3.02 Health Department: The Newton County Health Department.
- 3.03 Detailed Design: The sketch drawing of a wastewater treatment system with all calculations, alterations, lengths, depths and other information as needed.
- 3.04 Health Officer: The Administrator of the Newton County Health Department or authorized representative.
- 3.05 Emergency Condition: A condition of such extreme nature which presents an immediate danger to public health, requiring immediate correction without the necessary time to apply for the required permit as set forth herein.

- 3.06 Health Hazards: Any condition which is known to cause disease or harm to a person, community or the environment now or in the future.
- 3.07 Permit: A two (2) part written authorization issued by the Health Department. Part One of the permit is the Permit to Install which authorizes the permittee to construct, install or modify a wastewater treatment system. Part Two of the permit is the Permit to Use which allows the owner to operate/use the wastewater treatment system. A permit will not be issued unless Part One and Part Two have been signed by the Health Officer.
- 3.08 Site Evaluation. An evaluation to determine soil conditions (properties and permeability), slope, existence of lowlands, surface depressions, rock outcrops and sinkholes, set back distances, depth of water table, locations of easements and underground utilities, amount of available area for installation and/or replacement of wastewater treatment system, location of dwellings, runoff water potential, and any potential for significant groundwater contamination.
- 3.09 Approved Tanks: Any tank approved by the Health Department. Metal tanks are not allowed.
- 3.10 Person: An individual, corporation, or other legal entity.
- 3.11 Stop Order: A written order issued by the Health Officer to stop all construction, installation, modification or operation of a wastewater treatment system.
- 3.12 Board of Appeals: Board of Appeals as defined in SECTION 11.
- 3.13 Addressing System: The address shall consist of the information needed by the health department as stated in the rules and regulations for this county. A verifiable 911 address must be provided.
- 3.14 Homeowner: Any person(s) who owns and occupies the house for the purpose of residence there. A person may obtain a homeowner permit(s) for one (1) home within a two (2) year period.
- 3.15 Contactor: Any person building a house or a building for the purpose of selling, renting, or leasing.
- 3.16 Installer: Any person excavating the land for the purpose of or with the intent of installing, modifying, repairing, or replacing a wastewater treatment system.
- 3.17 Wastewater Treatment System: A wastewater treatment system, or part of a system, serving a dwelling(s) or other establishment(s), which utilizes subsurface soil treatment and disposal.

- 3.18 **Imminent Health Hazard:** A condition which is likely to cause an immediate threat to life or a serious risk to the health, safety, and welfare of the public if immediate action is not taken, and/or a condition resulting when a wastewater treatment system has failed and may be contaminating the surface water or groundwater or causing a nuisance and is likely to cause a threat to life due to prolonged exposure. For purposes of this definition, prolonged exposure is defined as the amount of time given for correction of the violation.
- 3.19 **Nuisance:** Sewage, human excreta or other human organic waste discharged or exposed to the owner's land or any other land from a wastewater treatment system in a manner that makes it a potential instrument or medium for the breeding of flies and mosquitoes, the production of odors, or the transmission of disease to or between a person or persons, or which contaminates surface water or groundwater.
- 3.20 **Aggrieved Party:** A person who has a legitimate cause for concern of their health caused by a nuisance, an imminent health hazard or environmental hazard such as surfacing sewage effluent, sewage effluent not contained on the property, environmental contamination of surface or groundwater, direct contamination of well, or other conditions deemed as a potential health hazard by the Health Department.
- 3.21 **Easements:** The wastewater treatment system shall be on the property owned by the person owning the system. However, easements may be necessary at times and shall be obtained permitting the use and unlimited access for inspection and maintenance of all portions of the system. Easements shall remain valid as long as the system is repaired and shall be recorded with the County Recorder of Deeds. Wastewater treatment systems installed under easements shall comply with the requirements of this ordinance.
- 3.22 **Notice of Non-Compliance:** A written notice issued by the Health Officer if a wastewater treatment system has not been installed according to the minimum standards of this ordinance.
- 3.23 **As-Installed Drawing:** A drawing showing how the wastewater treatment system was installed with the installer's signature and date drawing was received.
- 3.24 **As-Repaired Drawing:** A drawing showing the repairs made to the wastewater treatment system with the installer's signature and date drawing was received.
- 3.25 **Variations:** An allowance to install or repair a wastewater treatment system when the requirements for setback distances, minimum areas for infiltrative surface, or the minimum distance between the infiltrative surface and restrictive feature or bedrock cannot be complied with. A variance may be granted by the variance committee on a case-by-case basis.

- 3.26 Special Use Permit: An allowance to install or repair a wastewater treatment system for a specified limit of time for conditions other than those granted under a variance.
- 3.27 Existing Systems in conjunction with rebuilding or replacing structures: A wastewater treatment system that had been in use at the time the home or structure was destroyed.

SECTION 4. PROHIBITIONS. No person shall:

- 4.01 Construct, install, or modify, any wastewater treatment system without the permit required herein.
- 4.02 Construct, install, or modify, any wastewater treatment system when the permit has expired or has been suspended or revoked.
- 4.03 Fail to comply with a STOP ORDER/OR NOTICE OF NON-COMPLIANCE issued pursuant to this ordinance.
- 4.04 Construct, install, modify or operate any wastewater treatment system in violation of this ordinance or in violation of any construction, modification or operation permit issued by the Missouri Department of Natural Resources (DNR) or any other Federal or State agency.
- 4.05 Live, work or assemble in any building or assemble at any public gathering of six (6) or more hours in duration where sanitary disposal of all human wastes and domestic sewage is not provided by methods or devices approved by the health department. It shall be the responsibility of the property owner to comply with this section.
- 4.06 Operate a wastewater treatment system or transport and dispose of septage removed therefrom in such a manner that may result in the contamination of surface water or groundwater or present a nuisance or imminent health hazard to any person or property owner and that does not comply with the rules and regulations promulgated under this ordinance.
- 4.07 Knowingly allow an existing or newly constructed wastewater treatment system to violate any portion of this ordinance, or the rules and regulations, or present a nuisance, or health hazard as defined in this ordinance.
- 4.08 Remove, deface, destroy, damage, or alter any sign, notice or order posted by the Health Officer.

SECTION 5. PERMIT TO INSTALL.

- 5.01 Any person engaged in construction, installation or renovation of any wastewater treatment system or tank shall obtain a permit from the Newton County Health Department.
- 5.02 The applicant shall provide the information needed as stated in the rules and regulations for this county.
- 5.03 Individual wastewater treatment systems shall be approved as to the type, design, and capacity of system with the health department prior to issuance of the Permit to Install in accordance with the current MODOH 19 CSR 20-3.060, Missouri Clean Water Act, and the rules and regulations of Newton County.
- 5.04 The wastewater treatment system shall be constructed by an installer registered by the Health Department, except as specified in Section 7.03.
- 5.05 The permit application shall be signed by the owner/representative and the installer.
- 5.06 Any applicant knowingly providing false information on the application shall be in violation.
- 5.07 The wastewater treatment system shall be constructed according to the Permit to Install.
- 5.08 An 'as-installed' or 'as-repaired' drawing is required prior to issuing Part Two (Permit to Use) of the permit.
- 5.09 A written request for a variance must be submitted by the homeowner.
- 5.10 A Special Use Permit may be granted by the Board of Trustees.

SECTION 6. STOP ORDER, NOTICE OF NON-COMPLIANCE.

- 6.01 A STOP ORDER may be issued by the Health Officer when the system is causing an imminent health hazard as declared by the Health Officer.
- 6.02 A NOTICE OF NON-COMPLIANCE may be issued by the Health Officer for non-compliance with this ordinance. This notice may be attached to the property deed at the County Recorder of Deeds office.

SECTION 7. REGISTRY OF PERSONS AND BUSINESSES ENGAGED IN WASTEWATER TREATMENT SYSTEMS PROJECTS.

7.01 Every person engaged in the design, construction, installation, or modification of wastewater treatment systems; sale or manufacturing of tanks; or tank cleaning, within this county shall apply for registration with the Health Officer.

7.01 (1) Lists of registered personnel shall be provided. The lists will show the category under which the person is registered: a) Conventional Systems Installer; b) Advanced Systems Installer; c) Suspended or revoked personnel; d) Soil Scientist; e) Engineer; or f) Tank Cleaner.

7.01 (2) Any person(s) wanting to register with the county as an installer, general or advanced, or soil scientist must provide proof of current registration with the State of Missouri and the Missouri Department of Health.

7.02 The Board of Trustees may adopt rules and regulations, establishing qualifications and minimum standards of experience and knowledge for persons desiring to register under this ordinance.

7.03 A homeowner may install the wastewater treatment system serving as their residence once the homeowner demonstrates proper knowledge of installing a wastewater treatment system.

7.04 An applicant for registration shall demonstrate thorough knowledge of the Health Department's minimum standards for construction of wastewater treatment systems.

7.05 An applicant shall be registered specifically for construction of advanced systems.

7.06 An applicant shall be able to guarantee the workmanship and material on all installations for one (1) year.

7.07 An applicant providing false information or failing to comply with any and or all regulations, rules, orders, and decisions of the Health Department relative to the type of systems installed, constructed, or maintained shall be subject to termination or suspension.

7.08 An applicant installing any wastewater treatment system without the proper permit shall be subject to termination or suspension.

7.09 An applicant shall provide any and or all installation or construction data requested by the Health Department and shall maintain complete and accurate records of each installation or repair for a period of not less than one (1) year.

- 7.10 An applicant shall report promptly to the Health Officer any conditions not in accordance with the permit.
- 7.11 Any person whose application for registration under this section has been denied will be notified in writing as to the reasons for denial and said person may appeal pursuant to Section 11 of this ordinance.
- 7.12 Whenever the Health Officer determines that a person with a valid registration has violated any provision of this ordinance, or any of the rules and regulations adopted by the Board of Trustees, the Health Officer may recommend to the Board of Trustees, that said registration be suspended or revoked. If the Board of Trustees finds that the Health Officer's recommendation has merit, then the Board of Trustees shall schedule a hearing on the proposed suspension or revocation after giving the said person not less than ten (10) days notice of said hearing. Any person aggrieved by the decision of the Board of Trustees may appeal to the Board of Appeals as stated in Section 11.02.

SECTION 8. TANK CLEANING STANDARDS.

- 8.01 Inspection of equipment and disposal location – The Health Officer shall inspect or cause to be inspected the equipment of the Registered Tank Cleaner for the purpose of determining if the tank cleaner's equipment is in good operating condition and if the same is being operated and maintained in a sanitary and healthful manner, and in compliance with this ordinance. The disposal of wastewater or sewage from the tank truck shall be emptied by using hoses and connections that are approved by the Health Department.
- 8.02 The Registered Tank Cleaner shall have an agreement, on file with the Health Department, from the municipality where the wastewater will be disposed of and said disposal site must be approved by the Department of Natural Resources (DNR) and the Newton County Health Department for proper wastewater disposal. The Registered Tank Cleaner must use one the following methods for disposal:
- 8.02 (1) Land application permitted by the Department of Natural Resources (DNR).
 - 8.02 (2) Lagoon permitted by the Department of Natural Resources (DNR).
 - 8.02 (3) Discharge in municipal treatment plant permitted by the Department of Natural Resources (DNR).

SECTION 9. POWER AND AUTHORITY OF INSPECTORS.

- 9.01 The Health Officer, bearing proper credentials or identification, shall be permitted to enter all properties for the purposes of inspection, observation, measurement, sampling and testing in accordance with the provisions of this ordinance. This shall include facilities permitted by another government entity.
- 9.02 The Health Department shall have the power and duty to:
- 9.02 (1) Promulgate such rules and regulations as are necessary to carry out the provisions of this ordinance.
 - 9.02 (2) Cause investigations to be made when a violation of any provision of this ordinance or the rules and regulations promulgated under this ordinance is reported to the health department.
 - 9.02 (3) Enter at reasonable times, after receiving a complaint and determining probable cause that a violation exists, upon private or public property for the purpose of inspecting and investigating conditions relating to the administration and enforcement of this ordinance and the rules and regulations promulgated under this ordinance.
 - 9.02 (4) Authorize the trial and experimental use of innovative systems for wastewater treatment systems with such conditions as the department may set.
 - 9.02 (5) Issue a "Notice of Imminent Health Hazard" when any of the conditions defined in Section 3.18 exist.

SECTION 10. PENALTIES.

- 10.01 Any person found to be violating any provision of this ordinance shall be served by the Health Department with a written notice, via certified mail, or in person, stating the nature of the violation and providing a reasonable time limit for the satisfactory correction hereof. The offender shall, within the period of time stated in such notice, permanently cease all violation of this ordinance.
- 10.02 Any homeowner who does not have the proper permit(s) issued by the Health Department for a wastewater treatment system in this county is in violation of this ordinance.
- 10.03 Any person violating any of the provisions of this ordinance shall become liable to the Health Department for any expenses, loss or damage incurred by the Health Department by reason of such violation.

- 10.04 The statute of limitations commences when a person has installed a system without a proper permit.

SECTION 11. APPEALS.

- 11.01 The Board of Appeals shall consist of five (5) members. The Board of Trustees and the County Commission shall appoint one (1) representative each. The remaining three (3) members shall be jointly appointed by the Board of Trustees and the County Commission.
- 11.02 Any person aggrieved by the decision of the Board of Trustees may appeal to the Board of Appeals by filing a written application with the Health Officer within ten (10) days after being notified of the decision.
- 11.03 The Board of Appeals shall schedule a hearing for the appeal and shall notify the aggrieved person at least ten (10) days prior to the hearing.
- 11.04 The appeal hearing to the Board of Appeals shall be conducted in accordance with the Board of Appeals adopted rules and regulations.

SECTION 12. WASTEWATER TREATMENT SYSTEM PERMIT FEES. Wastewater treatment system permit fees are non-refundable. All fees are based on the Newton County Fee Ordinance #95-7 (see attached) and are subject to annual revision. Fees are required for the following:

- 12.01 Single family dwelling permit for one (1) single family dwelling per wastewater Treatment system. (see Attachment A)
- 12.02 Non-single family dwelling permit for systems other than single family dwellings. (see Attachment A)
- 12.03 Repair permit for replacing damaged parts only. (see Attachment A)
- 12.04 Registered Engineers, Registered Soil Scientists, Registered Contractors, Registered Tank Cleaners, and Registered Wastewater Treatment Installers (Conventional and Advanced Systems). Registration fees are due annually. (see Attachment A)
- 12.05 The fees for any single family dwelling wastewater treatment system may be waived by the Health Officer if the fees would cause undue hardship on the permit applicant. The applicant shall provide the proof this this will cause an undue hardship.

SECTION 13. SEVERABILITY.

13.01 If any article, chapter, section, clause or phrase of this regulation is, for any reason, held to be invalid by any court of competent jurisdiction, such decision shall not affect the remaining portions of this regulation.

13.02 No statement contained in this article shall be construed to interfere with any additional requirements that may be imposed by the Health Department.

SECTION 14. LOAN EVALUATIONS. The loan evaluation program and the registration of loan evaluators and inspectors is overseen by the Missouri Department of Health at the state level.

SECTION 15. FACILITIES PERMITTED BY ANOTHER GOVERNMENT ENTITY AND NOT INSPECTED BY THE HEALTH DEPARTMENT.

15.01 A copy of approval for the construction issued by the Missouri Department of Natural Resources and a copy of the engineering plans as approved by the Missouri Department of Natural Resources (DNR) shall be provided to the Health Department for a commercial wastewater treatment system(s) with a maximum daily flow of three thousand (3,000) gallons per day or greater.

**ORDINANCE OF THE COUNTY OF NEWTON
METHOD OF CALCULATION OF FEES TO SUPPORT
PUBLIC HEALTH ACTIVITIES**

Whereas the Eighty-fifth General Assembly Enacted Senate Bill 68 to enable county health centers to charge reasonable fees for public health activities, and

Whereas Section 67.042 RSMo (1988 Supp.) is a duly enacted exception to Article X, Section 22 of the Missouri Constitution allowing fees to be assessed for the offset for the actual cost to provide a service and

Whereas otherwise fees which are set simply to generate revenues at the local level, are to subject to the Article X, Section 22 voter approval process, it is essential that any fees set by Newton County Health Department Board of Trustees shall be done in accordance with the following formula so that cost justification of the fee will be readily available to defend any and all challenges thereto whether based on Article X, Section 22 or some other equity theory, and

Whereas any allowable fee to offset the actual provision of service that would not be challengeable under the Hancock Amendment must further be reduced in order to meet legislative objectives of Senate Bill 68 which was to all local health centers to charge fees for services, but not such a level of fees as would deny personal health services to those unable to pay nor to impede the prevention or control of communicable diseases, and

Therefore, be it ordained by the Newton County Health Department Board of Trustees that any such fees charged by the county health center shall be calculated in accordance to the following formula:

Total cost of Provision of Service minus
Total Local Tax Revenue Assignable or Identifiable to the Service minus
Total State Revenue Assignable and Identifiable to the Service minus
Total Federal Funds Assignable or Identifiable to the Service equals

Net Unreimbursed Expenses
Total Units of Service =

Maximum Allowable Fee Under Hancock

Which Must Further Be Modified Downward
So As Not To Deny Personal Health Services To Those Unable To Pay Not To Impede The
Prevention Or Control Of Communicable Diseases

DEFINITIONS

“Units of Service” is a logical, measurable and appropriate division of public activity for which the 85th General Assembly, through its duly enacted Senate Bill 68, intended county health centers to charge fees for the provision of said public health activities.

“Total Costs of Service” is the total of all costs whether direct or indirect, variable or fixed, for which accurate and defensible documentation can be made in accordance with recognized standards of accounting that thereby can justifiably and accurately assign costs that have been incurred in order to provide the public health activity or service in question.

“Reasonable Fee” is a fee not challengeable under Article X, Section 22 of the Missouri Constitution as a non-voter approved fee generating revenue not offsetting the cost provision of the service as required by 67.042 RSMo (1988 Supp.) and has been reduced and/or put on a sliding scale so as not to deny personal health services to those unable to pay such fees or impede the prevention or control of communicable diseases.

Compliance With County Budget Law

Newton County Health Department Board of Trustees hereby agree to employ the formula contained in this ordinance in such a manner as to comply with the filing requirements contained in Section 50.140 RSMo (1986).

County Treasurer’s Duty To Keep Subdivided Funds

Pursuant to Section 54.140 and Section 54.145 the County Treasurer shall account for fees covered by this ordinance so that funds shall be created which shall be divided for service for subsequent expenditure thereon in subsequent fiscal years. The county commission shall not exercise its power to transfer unencumbered appropriations in the last two (2) months of a fiscal year as contained in Section 50.630 RSMo (1986).

Amendments and Changes in Fee Schedules

Nothing in this ordinance shall prevent the Newton County Health Department Board of Trustees of the county health center to raise or lower fees as may be deemed financially or legally necessary during the course of the fiscal year. Nothing in this ordinance shall prevent the Newton County Health Department Board of Trustees or the county health center from adding new services with new fees or subtract the imposition of fees for discontinued services. The Newton County Health Department Board of Trustees and the county health center shall certify such amendments or changes in the fee structure to the county treasurer with appropriate recommendations and amendment or changes to the county’s budget.

Attachment A
 Newton County Health Department
 Environmental Fee Schedule
 (Revised 2021)

Service	Fee Schedule
Single Family Dwelling Septic Permit	\$150.00
Non-Single Family Dwelling Septic Permit	\$225.00
Repair Septic	\$30.00
Official Bacteria Water Sample (Health Dept. Collecting)	\$30.00
Nitrate	\$15.00
Unofficial Bacteria Water Sample (Individual Collecting)	\$25.00
Nitrate	\$10.00
Lead/Cadmium/Zinc (Health Dept. Collecting)	\$30.00
Tattoo Permit (Annual Fee)	\$100.00
High risk food establishment (Annual Fee)	\$250.00
Medium risk food establishment (Annual Fee)	\$175.00
Low risk food establishment (Annual Fee)	\$100.00
Mobile food unit (Annual Fee)	\$100.00
Temporary event food stand (Fee per event)	\$25.00/Event
Septic System General Installer Registration (Annual Fee)	\$30.00
Septic System Advanced Installer Registration (Annual Fee)	\$40.00
Septic Tank Cleaner Registration (Annual Fee)	\$30.00
Soil Scientist Registration (Annual Fee)	\$30.00

DEFINITIONS. Definitions as set forth in the Missouri Clean Water Law and MODOH 19 20-3.060 shall apply to those terms where used in this rule unless the context requires otherwise or as noted in these standards. For the purposes of these standards, certain standards, terms, or words used here shall be interpreted as follows. The word **shall is mandatory**. All distances, unless otherwise specified, shall be measured horizontally.

1. **Aeration Unit** - Any tank which utilizes the principle of oxidation in the decomposition of wastewater by the introduction of air into the wastewater.
2. **Alluvium** - Soil parent material which was transported and deposited in a running water setting.
3. **Advanced Systems** - An individual wastewater treatment system employing methods and devices as presented in **Subsection II I** of these standards.
4. **Baffle** - A device installed in a tank for proper operation of the tank and to provide maximum retention of solids. This includes vented sanitary tees and submerged pipes in addition to those devices normally called baffles.
5. **Bedrock** - That layer of parent material which is consolidated and unweathered.
6. **Bedroom** - Any room within a dwelling that might reasonably be used as a sleeping room or as designated in the blueprints of the dwelling.
7. **Black Water** - Liquid waste carried from a dwelling or other establishment, which contains organic wastes, including excreta or other body wastes, blood or other body fluids, and garbage; excluding bathing and laundry.
8. **Building Sewer** - That part of the drainage system which extends from the end of the building drain and conveys its discharge to a wastewater treatment system.
9. **Capacity** - The liquid volume of a tank using inside dimensions below the outlet.
10. **Distribution Pipes/Lateral Lines** - Perforated pipes that are used to distribute tank effluent in a soil treatment system.
11. **Dosing Chamber (or pump pit or wet well)** - A tank or separate compartment following the tank which serves as a reservoir for the dosing device.
12. **Dosing Device** - A pump, siphon or other device that discharges tank effluent from the dosing chamber to the soil treatment system.
13. **Dwelling** - Any building or place used or intended to be used by human occupants.
14. **Effluent** - Any wastewater or other substance flowing out of or discharged from a tank, other wastewater treatment device or a pipe.

15. **Environmental Public Health Specialist (EPHS)** - A person registered as an EPHS by the Missouri Board of Certification for Environmental Health Professionals or the National Environmental Health Association or employed as an EPHS by the state or local health department.
16. **Existing System(s)** -
 - a. For loan evaluations, are wastewater treatment systems that have been in use for at least six (6) continuous months.
 - b. In conjunction with rebuilding or replacing structures, are wastewater treatment systems that had been in use at the time the home or structure was destroyed.
17. **Geologist** - A person that meets the requirements defined in Chapter No. 256 of the Missouri Statutes.
18. **Gravelless System** - An absorption system recognized and approved by the health department as an acceptable method of subsurface disposal of wastewater without the use of gravel, such as a chamber system or gravelless pipe.
19. **Gray Water** - Liquid waste, specially excluding toilet, hazardous, culinary and oily wastes, from a dwelling or other establishment which is produced by bathing, laundry, or discharges from floor drains.
20. **Grease Trap** - A device designed and installed to separate and retain oils and fats from normal wastes while permitting normal wastes to discharge into the drainage system by gravity.
21. **Holding Tank** - A watertight tank for storage of wastewater until it can be transported to a point of approved treatment and disposal.
22. **Impermeable** - With regard to bedrock, a bedrock having very few cracks or crevices and having a vertical permeability less than one inch (1") in twenty-four (24) hours shall be considered impermeable. With regard to soils, a soil horizon or layer having a vertical permeability less than one inch (1") in twenty-four (24) hours shall be considered impermeable.
23. **Intermittent Sand Filters** - A bed of granular material twenty-four to thirty-six inches (24-36") deep underlain by graded gravel and collecting tile. Wastewater is applied intermittently to the surface of the bed through distribution pipes or troughs and the bed is underdrained to collect and discharge the final effluent. Uniform distribution is normally obtained by dosing to flood the entire surface of the bed. Filters may be designed to provide free access (open filters) or may be buried in the ground (buried filters or subsurface sand filters). Effluent from intermittent sand filters shall be discharged to a soil absorption system.
24. **Lateral Rock** - Clean rock, washed creek gravel, or similar insoluble, durable, and decay-resistant material free from dust, sand, silt, or clay. The size shall range from one inch to three inches (1"-3"). If limestone, dolomite or other crushed white rock is used, it shall be washed and be a minimum size of one and one-half inches (1 1/2").

25. **Mottling** - A zone of chemical oxidation and reduction activity appearing as splotchy patches of red, brown, orange, and gray in the soil.
26. **Mound System** - A system where the soil treatment area is built above the ground to overcome limits imposed by proximity to water table or bedrock or by rapidly or slowly permeable soils.
27. **Other Establishment** - Any public or private structure other than a dwelling which generates wastewater.
28. **Plastic Limit** - A soil moisture content below which the soil may be manipulated for purposes of installing a soil treatment system and above which manipulation will cause compaction and puddling.
29. **Professional Engineer** - An engineer holding a current license to practice from the Missouri Board for Architects, Professional Engineers and Land Surveyors, and having a background in soils, wastewater, and geology.
30. **Rock Fragments** - The percentage of rock fragments in a soil that are greater than two millimeters (2 mm) in diameter or retained on a No. 10 sieve which may include chert, sandstone, shale, limestone or dolomite. The amount of rock fragments in a soil is of a concern in areas of residual soils overlying highly permeable bedrock.
31. **Septage** - Those solids and liquids removed during periodic maintenance of a tank.
32. **Tank** - Any watertight, covered receptacle designed and constructed to receive the discharge of wastewater from a building sewer, separate solids from liquid, digest organic matter, store liquids through a period of detention and allow the clarified liquids to discharge to a soil treatment system. Includes, but is not limited to, septic tanks and aeration units and shall be approved by the health department.
33. **Setback** - A separation distance measured horizontally.
34. **Wastewater** - Any water carried domestic waste, exclusive of footings and roof drainage. Domestic waste includes, but is not limited to, liquid waste produced by bathing, laundry, culinary operations, liquid wastes from toilets and floor drains and specifically excludes animal waste and commercial process water. Also known as sewage.
35. **Flow-rate** - Flow as determined by measurement of actual water use or, if actual measurements are unavailable, as estimated by the best available data provided by **TABLE II** in **Subsection II. D** of these standards.
36. **Tank Effluent** - That liquid which flows from a tank under normal operation.
37. **Sinkhole** - Any depression in the surface of the ground, with or without collapse of adjacent rock, that provides a means through which surface water can come into contact with subsurface water. Sinkhole depressions may be gradual or abrupt; they may or may not have a well defined eye.

38. **Site** - The area bounded by the dimensions required for the proper location of the wastewater treatment system.
39. **Slope** - The ratio of vertical rise or fall to horizontal distance.
40. **Soil Characteristics** - Those soil characteristics which preclude the installation of a conventional system, including, but not limited to, evidence of water table or bedrock closer than three feet (3') to the ground surface. Also the amount of rock fragments in areas of significant potential for groundwater contamination.
41. **Soil Scientist** - An individual who has a minimum of fifteen (15) semester credit hours of soils course work including a minimum of three (3) hours in the area of soil morphology and interpretations, and has a minimum of two (2) years of field experience.
42. **Soil Textural Classification** - Soil particle sizes or textures specified in this rule refer to the soil textural classification in the most recent U. S. Department of Agriculture Soil Survey Manual Handbook.
43. **Soil Treatment Area** - That area of trench or bed bottom which is in direct contact with the trench rock of the soil treatment system.
44. **Soil Treatment System** - A system where tank effluent is treated and disposed of below ground surface by filtration and percolation through the soil. It includes those systems commonly known as seepage bed, trench, drain field, disposal field, or lateral field, and includes mound and low pressure pipe systems. See Wastewater Treatment Systems.
45. **Conventional System** - An individual wastewater treatment system employing a building sewer, tank, and the soil treatment system commonly known as seepage bed or trenches, drainfield or leachfield.
46. **Toilet Waste** - Fecal matter, urine, toilet paper, and any water used for flushing.
47. **Valve Box** - Any device which can stop tank effluent from flowing to a portion of the treatment area. This includes, but is not limited to, caps or plugs on distribution or drop box outlets, divider boards, butterfly valves, gate valves, or other mechanisms.
48. **Sewage** - Same as wastewater.
49. **Wastewater Stabilization Pond** - A sealed earthen basin which uses the natural unaided biological processes to stabilize wastewater (also known as a lagoon).
50. **Wastewater Treatment System (WTS)** - A system, or part of a system, serving a dwelling(s) or other establishment(s), which utilizes subsurface soil treatment and disposal.
51. **Water Table** - The highest elevation in the soil where all voids are filled with water, as evidenced by presence of water soil mottling or other information. This includes perched and zones of saturation for long periods of time.

52. Watertight - Constructed so that no water can get in or out below the level of the outlet.

I. WASTEWATER TREATMENT SYSTEMS (WTS) PROCEDURES.

A. Application For Permit.

1. **Permits.** The wastewater treatment system permit is a two-part written authorization issued by the health department.

a. Permit to Install.

(1) Part One of the permit is the Permit to Install. This part gives permission to install the wastewater treatment system.

(2) Part Two of the permit is the Permit to Use. This allows the owner to use the wastewater treatment system once all of the requirements have been satisfied, and the As-Installed Drawing is received by the Health Officer.

b. Permit to Repair.

(1) Part One of the Repair Permit states the problem and the proposed repairs. This part gives permission to repair the wastewater treatment system.

(2) Part Two of the Repair Permit is the Permit to Use. This allows the owner to use the wastewater treatment system once all of the requirements have been satisfied, and the As-Repaired Drawing is received by the Health Officer.

2. Projects Requiring Permits.

a. Construction of a new system.

b. Repairing an existing system. Repairs are for the replacement of small sections due to accidental damage and for the installation of tanks.

c. Rebuilding or replacing structures. In cases where home or other structure is destroyed by fire or other cause, the existing wastewater treatment system in use at the time the home or structure was destroyed, may be used to serve the replacement structure, provided the occupancy and use of the structure or home is adequate for the existing system and the existing system was functioning properly at the time the building was destroyed. If the existing wastewater treatment system was not functioning properly, or is inadequate for use, the health department may require the system to be repaired or replaced. It is the homeowner's responsibility to provide the details of the system to the health department for this determination.

3. **Permit Application Information.** The applicant must provide all information requested on the application form. If additional information is necessary to properly evaluate the application, the applicant will be notified. Processing of the application cannot be completed until all requested information is received, and the application fee is paid in full.

a. Permit application forms are available at the Newton County Health Department, located at 812 W. Harmony, Neosho, Missouri.

(1) The front page of the application is to be completed by the owner/representative.

(2) The back page of the application is to be completed by the installer.

Attachment A
 Newton County Health Department
 Environmental Fee Schedule
 (Revised 2021)

Service	Fee Schedule
Single Family Dwelling Septic Permit	\$150.00
Non-Single Family Dwelling Septic Permit	\$225.00
Repair Septic	\$30.00
Official Bacteria Water Sample (Health Dept. Collecting)	\$30.00
Nitrate	\$15.00
Unofficial Bacteria Water Sample (Individual Collecting)	\$25.00
Nitrate	\$10.00
Lead/Cadmium/Zinc (Health Dept. Collecting)	\$30.00
Tattoo Permit (Annual Fee)	\$100.00
High risk food establishment (Annual Fee)	\$250.00
Medium risk food establishment (Annual Fee)	\$175.00
Low risk food establishment (Annual Fee)	\$100.00
Mobile food unit (Annual Fee)	\$100.00
Temporary event food stand (Fee per event)	\$25.00/Event
Septic System General Installer Registration (Annual Fee)	\$30.00
Septic System Advanced Installer Registration (Annual Fee)	\$40.00
Septic Tank Cleaner Registration (Annual Fee)	\$30.00
Soil Scientist Registration (Annual Fee)	\$30.00

B. Construction

1. **Approved Permit.** Upon notification of an approved Permit to Install, the applicant may construct the system as designed in the permit in accordance with the ordinance.
2. **Homeowner.** If a homeowner installs the wastewater treatment system, the homeowner must comply with all of the requirements of this ordinance, and the rules and regulations for this county. If a homeowner has anyone assisting with the wastewater treatment system in any fashion, the person(s) assisting shall be registered in this county. The registered installer becomes responsible for the system as specified in the ordinance. The permit shall have the installer's name and signature as specified in the permit section of the regulations.
3. **Modification.** If the installer should discover after beginning construction that the system cannot be constructed in accordance with the permit to install, the applicant may request approval for a modification of the plans set forth in the application. Such a request for modification could involve a modification of the materials and/or procedures specified in the permit application and should specify alternate materials and/or procedures which meet the criteria of the regulations. The Health Officer shall process the request for modification in the same manner described in the procedures set forth in **Section I. A. 5.** of these rules.
4. **Notification.** The installer shall notify the Health Officer at least twenty-four (24) hours before final evaluation is needed. Evaluations will be performed during normal business hours. No evaluation will be scheduled on weekends or holidays. After the allotted time period the system may be covered. The installer shall notify the Health Officer to cancel scheduled evaluations if the system will not be completely done at the appointed time. All notification must be made to the Health Officer during normal business hours. The telephone number is (417)451-6549.
5. **As-Installed or As-Repaired Drawing.** An As-Installed or As-Repaired Drawing signed by the installer, shall be provided to the health department before the Permit to Use will be issued.
 - a. Failure to provide or falsifying the drawing will result in suspension or revocation of the installer's registration.
 - b. Failure to acquire the Permit to Use could result in the homeowner being referred to the Prosecuting Attorney and/or having a Notice of Non-Compliance attached to the property records.
6. **Permit to Use.** The Permit to Use will be issued to the homeowner if the system was installed according to the permit.
7. **Non-Compliance.** The homeowner and installer will be served with a Notice of Non-Compliance if the system does not meet the permit requirements. See **Paragraph I.F.1.**

C. Permit Exceptions.

1. **Permit and Site Evaluation Expiration.** A permit and a site evaluation is valid for a limited time.
 - a. **Permit expiration.** Part One of the permit issued pursuant to this ordinance shall be valid for a period of one (1) year from the date of approval. An applicant may request renewal of part one of the permit for an additional one year period by filing a request for renewal in writing with the Health Officer before the date of expiration of the original permit. If the applicant fails to renew the permit by the expiration date, the permit shall expire and the applicant must request a new permit prior to the beginning or continuing construction of the system. No refund will be given on expired permits.
 - b. **Site evaluation expiration.** Site evaluations are considered valid for two years, provided the soil properties at the site are not altered by excavating, filling, tilling, compaction of soil in place by operation of heavy equipment; provided no dumping of chemicals or other compounds has occurred at the site; and provided the surface of the site has not been altered by construction or pavements.

2. **Special Use Permit.** Special use permits may be granted on a case-by- case basis for a specified limit of time. This type of permit is non-transferable. It is the homeowner's responsibility to provide the information needed for this type of permit. If there are any changes or modifications to the wastewater treatment system with a Special Use Permit, the permit becomes null and void, thus putting the system in violation. A Special Use Permit will not be granted for:
 - a. Smaller tank size.
 - b. A system that includes laundry facilities.

3. **Variance Request.** Variances may be considered and granted by the Newton County Variance Committee concerning property platted prior to January 1, 1996, with site limitations.
 - a. **Types of eligible projects with site limitations.**
 - (1) Repairs to wastewater treatment systems on property that was platted, designated, recorded, or came into existence prior to January 1, 1996.
 - (2) New wastewater treatment installation on property that was platted, designated, recorded, or came into existence prior to January 1, 1996.
 - b. Where variances have been allowed from the standards, the Variance Committee may require a higher level of pretreatment than that of a regular tank. At the discretion of the Variance Committee, on a case-by-case basis, and with relative assurance for protection of the public health and preservation of the quality of surface and groundwaters, variances may be granted for:
 - (1) Setbacks as specified in **Table I**.
 - (2) Minimum distance between infiltrative surface and restrictive feature or bedrock.
 - (3) Minimum areas of infiltrative surface. as shown in **Table V** and **Table VI**.

- c. Variance requirements. The landowner submits a written request (Variance Request No.1) for a variance to the Health Officer. Specific project information is required.
 - (1) The date that the property, as legally described, was platted, designated, recorded, or came into existence.
 - (2) A clear description explaining why the requirements of this rule cannot be complied with.
 - (3) Describe specific sections of this rule for which a variance is being requested.
 - (4) The existing and maximum occupancy.
 - (5) The existing water usage records, if any.
 - (6) Potential impact, if any, on neighboring property owners. Provide the names and mailing address of these property owners.
 - (7) Sufficient actual data to indicate that the effluent will not contaminate any drinking water supply, surface water, or groundwater used for drinking water.
- d. Variance conditions.
 - (1) These systems shall comply with all applicable requirements of these standards except where variances have been granted.
 - (2) Variances will not be granted if the result would cause non-compliance with the Missouri Clean Water Act or for a system which would require a discharge permit from the Missouri Department of Natural Resources.
 - (3) Set back distances for wastewater stabilization ponds (lagoons) will be considered applicable to advanced systems. The required footage of the soil absorption system following advanced systems may be reduced by up to one-third (1/3) of that required for a conventional wastewater treatment system.
 - (4) The five (5) working days review period does not apply for a variance.
- e. Appeal process. When a variance request (Variance Request No. 1) has not been approved by the Variance Committee, the landowner has the right to appeal, first to the Board of Trustees, then to the Board of Appeals.
 - (1) The landowner submits a written request (Variance Request No. 2) to the Health Officer to schedule a meeting with the Board of Trustees.
 - (2) The owner submits a written request (Variance Request No. 3) to the Health Officer to schedule a meeting with the Board of Appeals. This is the final appeal.

D. Registration Revocation or Suspension. The Board of Trustees may revoke or suspend a person's registration upon determination that a violation of this ordinance has occurred.

1. Notification. Whenever the Health Officer determines that a person with a valid registration has violated any provision of this ordinance, or any of the rules adopted by the Board of Trustees, the Health Officer may recommend to the Board of Trustees, that said registration be suspended or revoked. If the Board of Trustees finds that the Health Officer's recommendation has merit, then the Board of Trustees shall schedule a hearing on the proposed suspension or revocation after giving the said person not less than ten (10) days notice of said hearing. The Board of Trustees shall set the term of the revocation or suspension within ten (10) days of said hearing.

2. Suspension period. No Permit to Install; Permit to Repair; or Permit to Use will be issued while a registration is suspended or revoked.

3. **Appeal.** If the applicant wishes to appeal a suspension or revocation decision, it may be done in accordance with the provisions set forth in the ordinance.
4. **Warnings.** Warnings may be issued when deemed appropriate by the Health Officer. After the second warning the Health Officer will make a request to the Board of Trustees for a suspension or revocation order.
5. **Reinstate registration.** After a suspension or revocation of a person's registration, the person can be required to provide a performance bond payable to the health department and retake the required training course(s) prior to the reinstatement of any further registration.

E. Responsibilities.

1. Board of Trustees.

- a. Establish the rules for the ordinance.
- b. Conduct hearings when needed as stated in the ordinance.
- c. Appoint or serve as representatives on the Variance Committee for granting variances, and Special Use Permits.
- d. Adopt rules and procedures for Board of Appeals.
- e. Review the ordinance annually.
- f. Establish and maintain a data base.

2. Administrator.

- a. Participate in planning, developing, and coordinating the ordinance.
- b. Schedule hearings as needed and as stated in the ordinance.
- c. Send letters regarding complaints received.
- d. Provide needed information to Prosecuting Attorney, or the Board of Trustees.
- e. Implement the data base.

3. Environmental Public Health Specialist (EPHS).

- a. Provide information concerning wastewater treatment systems.
- b. Provide training for persons seeking registration in this county under the ordinance.
- c. Issue permits for wastewater treatment systems which meet the required standards as set forth in the ordinance.
- d. Perform evaluations to verify the installer has installed the system according to the permit(s) issued.
- e. Maintain records of permits issued and loan evaluations performed by this office for future reference.
- f. Investigate wastewater treatment system complaints received by this office, when needed.

4. **Installer.**
 - a. Attend classes as required for registration.
 - b. Register in Newton County.
 - c. Guarantee workmanship and materials on all installations for one (1) year.
 - d. Comply with all rules, regulations, orders, and decisions of the health department.
 - e. Obtain all required permits.
 - f. Provide all information requested by the Health Officer.
 - g. Maintain complete and accurate records of each installation.
 - h. Report to the Health Officer any violation of the ordinance.
 - i. Design a system and apply for a permit using a properly approved site evaluation.
 - j. Complete an As-Installed or As-Repaired Drawing once the wastewater treatment system is installed or repaired to obtain the Permit to Use.

5. **Homeowner.**
 - a. Comply with all rules, regulations, orders, and decisions of the health department.
 - b. Obtain a proper site evaluation.
 - c. Obtain all proper permits.
 - d. Report to the health department any violation of the ordinance.
 - e. Hire a registered installer for installing one's own system if homeowner does not demonstrate proper knowledge for installing own system.

6. **Contractor.**
 - a. Comply with all rules, regulations, orders, and decisions of the health department.
 - b. Obtain a proper site evaluation.
 - c. Hire a registered installer for installing system.
 - d. Obtain all proper permits.
 - e. Report to the health department any violation of the ordinance or rules and regulations.

7. **Tank Cleaner.**
 - a. Attend classes as required for registration.
 - b. Register in Newton County.
 - c. Schedule appointments with the Health Officer for inspection of trucks, equipment, and sites.
 - d. Provide all information requested by the Health Officer.
 - e. Maintain records for at least one (1) year.
 - f. File with the Health Officer all agreements and approvals for disposal of septage.
 - g. Comply with all rules, regulations, orders, and decisions of the health department.
 - h. Report to the Health Officer any violation of the ordinance.

8. **Soil Scientist.**
 - a. Attend classes as required for registration.
 - b. Meet state requirements for Missouri Department of Health (prior to step c.)
 - c. Register in Newton County.
 - d. Provide all information requested by the Health Officer.
 - e. Maintain records for each site evaluation performed for at least two (2) years.
 - f. Comply with all rules, regulations, orders, and decisions of the health department.
 - g. Report to the Health Officer any violation of the ordinance.

F. Administration of Ordinance.

1. **Notice of Non-Compliance.** A Notice of Non-Compliance will be submitted to the installer and homeowner if a wastewater treatment system has not been installed or repaired according to the permit.
 - a. This notice will apply to all wastewater treatment systems installed or repaired after September 1, 1995 and will state why the wastewater treatment system is not in compliance and that the Health Officer must be contacted in an effort to resolve the situation.
 - b. The Notice of Non-Compliance will be attached to the property records. Failure to make necessary corrections to the wastewater treatment system could jeopardize future legal transactions of this property (ie: bank loans).
 - c. The removal, destruction, alteration, or defacement of the Notice of Non-Compliance is in violation of the ordinance.

2. **Complaints.** A complaint must be received by the Health Officer before any action can be taken. Complaints can be submitted in writing; verbally; or anonymously.
 - a. The following information is needed to investigate a complaint.
 - (1) The date the complaint is made.
 - (2) Name, address, and telephone number of the person causing the complaint.
 - (3) Location of the complaint.
 - (4) Detailed description of the complaint.
 - b. Once a complaint is received, the Health Officer will proceed as follows:
 - (1) Investigate the complaint to determine if a violation of the ordinance does exist.
 - (2) If a violation does exist, the owner will be notified by letter or notice to contact the Health Officer in writing (by mail or in person). The contact must be within seven (7) days from receipt of the letter or notice and state how and when the problem is to be corrected.
 - (3) The proper permit shall be obtained prior to any work being performed. No more than thirty (30) days will be allowed without the Health Officer's approval.
 - (4) If the owner fails to contact the Health Officer within seven (7) days or the proper permit is not obtained, the matter may be referred to the Prosecuting Attorney and/or a Notice of Non-Compliance will be attached to the property records.

3. **Violations.** Any person violating any of the provisions of the ordinance could be referred to the Prosecuting Attorney.
 - a. Types of violations are:
 - (1) Creating a nuisance or imminent health hazard.
 - (2) Persistent violation of creating a nuisance or imminent health hazard.
 - (3) Construction or repair of a wastewater treatment system without a permit.
 - (4) Construction or repair without a permit and previously found guilty of same.
 - (5) Misrepresenting oneself as being registered in this county.
 - b. Any person found guilty of installing or repairing without a permit can be required to provide a performance bond before beginning another installation or repair. This requirement expires after two consecutive years of being found guilty.

- c. Any person found guilty of violating any portion of the ordinance may have their registration suspended or revoked and the person's name shall be listed on the suspended or revoked personnel list which will be made available to the public.

II. DESIGN AND CONSTRUCTION

A. General.

1. **Intent.** The intent of these standards is to provide minimum requirements for site evaluations, design, and construction of wastewater treatment systems in this county.
2. **Applicability.** For these standards, wastewater treatment system means all equipment and devices necessary for proper collection, storage, treatment, and disposal of wastewater from a dwelling or other facility producing wastewater flows of three thousand (3,000) gallons per day, or less. Included within the scope of this definition are building sewers, tanks, subsurface absorption systems, mound systems, intermittent sand filters, gravelless systems, and wastewater stabilization ponds.
3. **Responsibilities.**
 - a. The design, construction, operation, and maintenance of wastewater treatment systems shall be the responsibility of the designer, owner, developer, installer, or user of the system.
 - b. Actions of the representatives of the health department engaged in the evaluation and determination of measures required to comply with the provisions of the ordinance, and the rules and regulations shall in no way be taken as a warranty that wastewater treatment systems permitted will function in a satisfactory manner for any given period of time.

B. Site Evaluation:

1. **Evaluation.** All proposed sites for wastewater treatment systems shall be evaluated for the following:
 - a. Soil conditions, properties, and permeability.
 - b. Slope.
 - c. The existence of lowlands, local surface depressions, rock outcrops and sinkholes.
 - d. All required setback distances as required in TABLE I of this rule.
 - e. Flooding probability of surface water and depth to water table.
 - f. Location of easements and underground utilities.
 - g. Amount of available area for the installation of the system and an area for a replacement system, if needed.
 - h. Location of dwellings.
 - i. Runoff water potential, roads, streets, etc.
 - j. Any potential for significant groundwater contamination.

2. **Preliminary Soils Information.** The Newton County Soil Survey Book available from the health department can be used to gather preliminary soils data before the actual site evaluation is conducted. The information in the soils survey is **NOT** site specific and shall **NOT** be used in lieu of the actual site evaluation.
3. **Procedures for site evaluations.** All site evaluations shall be recorded and submitted on the standard form.
 - a. Soil Morphology (Soil Profile). This evaluation shall be conducted by a Missouri Department of Health Certified soil scientist, engineer, geologist, or environmental health professional to determine the required soil characteristics. This professional must be registered with the health department.
 - b. Soil Pit.
 - (1) A minimum of one soil pit shall be dug for each represented soil in the lateral field area. The hole for the tank shall **NOT** be used for the soil pit.
 - (2) Soil pits shall be dug to a depth of forty-eight inches (48") or as required to determine the soil characteristics.
 - c. Percolation Tests. The site evaluator may choose to conduct a percolation test for comparison, however the percolation test alone shall **NOT** be accepted or approved for a site evaluation.
 - d. All procedures shall be followed based on the procedures stated in the ordinance.
- C. **Minimum Set-Back Distances.** All wastewater treatment and disposal systems shall be located in accordance with the distances shown in **Table I**.

**TABLE I
SETBACK DISTANCES**

Minimum Distance in Feet From:	Tanks (1)	Disposal Area (2)	Wastewater Stabilization Ponds
Private water supply well.	50	100	100
Public water supply well (new construction).	300	300	300
Non-community type well (new construction).	300	300	300
Existing public wells (existing systems).	100	100	100
Classified stream, lake or impoundment.*	50	50	50
Stream or open ditch. (3)	25	25	25
Property lines.	10	10	75
Building foundation.	5	15	15
Basement.	15	25	25
Water line under pressure.	10	10	10
Suction water line.	50	100	100
Upslope interceptor drains.	---	10	10
Top of slope of embankments or cuts of 2 feet or more vertical height.	---	20	20
Other soil absorption system except repair area.	---	20	20
Inground swimming pools.	50	50	50
Caves, springs, or sinkhole rims.	50	100	500
Known mineshafts and abandoned wells. (4)	150	150	150

(1) Includes tanks, intermittent sand filters and dosing chambers.

(2) Includes subsurface absorption systems. Does not include wastewater stabilization ponds.

(3) Tanks and subsurface absorption systems shall never be located in the drainage area of a sinkhole.

(4) Unplugged abandoned wells or wells with less than 80' of casing depth. All abandoned wells must be sealed in accordance with the Division of Geology and Land Survey (DGLS) instructions.

* A classified stream is any stream that maintains permanent flow or permanent pools during drought periods and support aquatic life.

D. Flow Rates. Design of wastewater treatment systems for establishments or housing not identified in this part shall be determined using available flow data, water using fixtures, occupancy or operation patterns and measured data.

1. **Volume determination.** In determining the volume of wastewater from single family dwellings, the minimum flow rate shall be one hundred twenty (120) gallons per day per bedroom. The minimum volume of wastewater from each single family dwelling shall be two hundred forty (240) gallons per day. When the occupancy of a single family dwelling exceeds two (2) persons per bedroom, the volume of wastewater shall be determined by the maximum occupancy at a rate of sixty (60) gallons per person per day. Note: This calculation can be used only when the number of persons in the single family dwelling is known.
2. **Selected types of establishments.** TABLE II and III shall be used to determine the minimum design daily flow of wastewater required in calculating the design volume of wastewater treatment systems to serve selected types of establishments. The minimum design volume of wastewater from any establishment shall not be less than one hundred (100) gallons per day flow.
3. **Other establishments.** For housing developments other than a single family residence and other establishments, TABLE II shall be used to estimate the flow rate. Actual metered flow rate may be used. If metered flow rates are used, documentation from the public water supply serving an existing facility in similar locations shall be provided to the health department.
4. **Population to be served.** The figures in TABLE III shall be used in determining the population for which to design the wastewater treatment system. Lower-per-unit occupancies allowed when justified.
5. **Reduction in flow.** Reductions in design flow rates may be allowed on a case-by-case basis depending upon water conservation plans. Separate systems may be used for gray water and black water systems. Flow rate may be reduced up to forty percent (40%) for gray water systems when the blackwater is discharged to a holding tank and disposed off site or when waterless toilets are utilized. Minimum size gray water tank shall be one thousand (1,000) gallons.

TABLE II
MINIMUM FLOW RATE VOLUME

TYPE OF ESTABLISHMENT	FLOW RATE (gallons per day)
Residential Units	
Single family dwellings	120/bedroom
Multiple family dwellings (with laundry)	120/bedroom
without laundry	95/bedroom
Commercial and Assembly Facilities	
Transportation terminals (airports, etc.)	5/passengers
Laundromats	580/machine
Beauty salons/barber shops	125/chair
Bowling lanes	50/lane
Churches (without kitchen/day care/camp)	3/seat
with kitchen and no day care/camp	5/seat
Country clubs	20/member or guest
Employee (8 hour shift)	25/person
Factories (8 hour shift)	25/person
add for showers (per shift)	10/person
Marinas (without bathhouse)	10/boat slip
with bathhouse	30/boat slip
Motels/hotels (without kitchenettes)	120/room
with kitchenettes	175/person
Offices (per shift)	25/person
Service stations	250/toilet or urinal
24-hour service stations	325/toilet
Theaters: movies/music/auditorium/ drive-in	5/seat 15/vehicle space
Public parks (toilets/urinal only)	5/person
parks with showers	25/person
Retail stores (no food preparation)	200/1,000 sq. ft. area
Swimming pools, spas, and bathhouses	10/person
Warehouses	30/employee
Camps	
Construction or work camps	60/person
chemical toilets only	40/person
Summer camps (without kitchen)	25/person
Campgrounds (toilets/urinal only)	100/campsite
with RV water/sewer hookups	120/space

TABLE II (continued)
MINIMUM FLOW RATE VOLUME

TYPE OF ESTABLISHMENT	FLOW RATE (gallons per day)
Food or Drink Facilities	
*grease traps are required	
Bar without tap (no food preparation)	5/seat
with tap (no food preparation)	20/seat
Restaurants	40/seat or
(per sq. ft. of dining area, whichever is greater)	40/15 sq. ft.
24-hour restaurants	75/seat
Fast-food (paper service only)	5/customer
add shift employee	25/person
Meat markets	
a. per 100 sq. ft. floor area	50/gpd
b. add per shift employee	25/gpd
Institutional	
Boarding schools	60/person
Day care (excluding shift employees)	15/child
Hospitals (with laundry)	300/bed
Residential group homes (excluding shift emp.)	60/person
Rest homes (with laundry)	120/bed
without laundry	60/bed
Day schools (with food preparation only)	12/student
without food preparation	10/student
with food prep, gym, and showers	15/student

NOTE: Establishments with flows greater than three thousand gallons per day (3,000 gpd) are regulated under Chapter 644 RSMo, administered by the MDNR. Any system with flows greater than 3,000 gpd must obtain an operating permit from the MDNR. The health department shall have a copy of the letter of approval from the MDNR prior to beginning construction or repair.

**TABLE III
OCCUPANCY-PER-UNIT**

Type Unit	Persons/Unit
Residences	3.7
Apartments or condominiums	
(1 bedroom)	2.0
(2 bedroom)	3.0
(3 bedroom)	3.7
Mobile homes	3.0 - 3.7
Camper trailers (without sewer hookup)	2.5
with sewer hookup	3.0
Motels	3.0

E. **Sinkholes.** Sinkholes, loosing streams, and caves that commonly occur in karst topography provide avenues of contamination for groundwater. Any type of wastewater treatment system that is to be located in a karst area must be carefully designed to prevent contaminants from affecting the underlying groundwater supplies. The following requirements are intended to provide specific criteria for site evaluations, design and construction for any site upon which sinkholes or other karst features are located.

1. **Sinkhole Evaluation.** An evaluation including the following information shall be made for all sites upon which sinkholes or other karst features are fully or partially located. All evaluations shall be conducted by registered soil scientists, geologists, or engineers. However, the health department may require that a registered geologist evaluate the sinkhole and the health department may seek an evaluation from Missouri Dept. of Natural Resources - Division of Geology & Land Survey (DGLS). The site evaluation for the proposed individual wastewater treatment system must show the following items with respect to location of proposed construction, proposed or existing property lines, and existing structures:
 - a. Location and limits of the area of the sinkhole depression as determined by field surveys. Location of sinkholes based solely upon USGS 7-1/2 Minute Series Quadrangle Maps will not be considered sufficient unless field verified.
 - b. Location and elevation of the sinkhole eye.
 - c. Location and elevation of any solutional opening.
 - d. Topographic contours at maximum intervals of two feet (2') and spot elevations sufficient to determine the low point on the sinkhole rim and the high point of the sinkhole floor.

2. **Sinkhole Requirements.** Construction of new wastewater treatment systems in sinkholes shall not be approved. The setback from a sinkhole rim to any part of the system can be found in Table I. Exceptions will be made only in situations where it can be conclusively demonstrated that there are no practical alternatives to such construction. These situations will be considered on a case-by-case basis.

F. Building Sewers. Building sewers used to conduct wastewater from a building to a wastewater treatment system shall be constructed of pipe meeting the minimum requirements of American Society for Testing and Materials (ASTM) Standards, F789-85, Schedule 40 PVC or cast iron, all with approved type joints.

1. **Size.** Building sewers shall not be less than four inches (4") in diameter.
2. **Slope.** Building sewers shall be laid to the following minimum slope:
 - a. 4-inch sewer ----- 12 inches per 100 feet.
 - b. 6-inch sewer ----- 8 inches per 100 feet.
3. **Cleanouts.** An accessible cleanout shall be provided before the tank. An accessible cleanout shall be provided at least every one hundred feet (100') and at every change in direction or slope if the change exceeds forty-five degrees (45°). This includes before the tank and between the tank and the lateral field.
4. **Connection to the tank.** The pipe going into and out of the tank shall be:
 - a. Schedule 40 PVC, cast iron, or equivalent.
 - b. Extended a minimum of two feet (2 ft.) beyond the tank excavation hole.
 - c. A minimum of two feet (2 ft.) of earth dam between tank excavation hole and absorption trench.

G. Tanks. All liquid waste and washwater shall discharge into a wastewater treatment system. Roof, garage, footing, surface water, drainage, cooling water discharges and hazardous wastes shall be excluded from the wastewater tank. Backwash from water softeners and swimming pool filtration systems may be excluded from the wastewater tank. In such event of excluding swimming pool filter backwash, the MDNR shall be contacted for applicability of a discharge permit. All wastewater tank effluent shall be discharged to a soil absorption system that is designed to retain the effluent upon the property from which it originated.

1. **General.** All tanks must be constructed of concrete or other corrosive resistant material approved by the health department. All tanks regardless of material or method of construction shall be:
 - a. Watertight and designed and constructed to withstand all lateral earth pressures under saturated soil conditions with the tank empty.
 - b. Designed and constructed to withstand a minimum of two feet (2') of saturated earth cover above the tank top.
 - c. Resistant to corrosion or decay. Plastic or fiberglass tanks must be cushioned and anchored and will be approved on a case-by-case basis.
2. **Wastewater Treatment (WTS) Tanks.** Wastewater treatment tanks, regardless of material or method of construction, shall conform to the following criteria:
 - a. The liquid depth of any tank or its compartment shall not be less than thirty-six inches (36"). A liquid depth greater than six and one-half feet (6 1/2') shall not be considered in determining tank capacity.

- b. No tank or compartment shall have an inside, horizontal dimension less than twenty-four inches (24").
- c. Inlet and outlet connections of the tank shall be protected by baffles or sanitary tees.
- d. The space in the tank between the liquid surface and the top of the inlet and outlet baffles shall not be less than twenty percent (20%) of the total required capacity, except that in horizontal cylindrical tanks this space shall not be less than fifteen percent (15%) of the total required liquid capacity.
- e. Inlet and outlet baffles shall be constructed of acid-resistant concrete, acid-resistant fiberglass, or plastic.
- f. Sanitary tees shall be affixed to the inlet or outlet pipes with a permanent waterproof adhesive. Baffles shall be integrally cast with the tank, affixed with a permanent water-proof adhesive or affixed with stainless steel connectors top and bottom.
- g. The inlet baffle shall extend at least six inches (6") but no more than twenty percent (20%) of the total liquid depth below the liquid surface and at least one inch (1") above the crown of the inlet sewer.
- h. The outlet baffle and the baffles between compartments shall extend below the liquid surface a distance equal to forty percent (40%) of the liquid depth except that the penetration of the indicated baffles or sanitary tees for horizontal cylindrical tanks shall be thirty-five percent (35%) of the total liquid depth. They also shall extend above the liquid surface as required in **Paragraph II.G.2.d** of this rule. In no case shall they extend less than six inches (6") above the liquid surface.
- i. There shall be at least one inch (1") between the underside of the top of the tank and the highest point of the inlet and outlet devices.
- j. The inlet shall not be less than three inches (3") above the outlet.
- k. The inlet and outlet shall be located opposite each other along the axis of maximum dimension. The horizontal distance between the nearest points of the inlet and outlet devices shall be at least four feet (4').
- l. Sanitary tees shall be at least four inches (4") in diameter. Inlet baffles shall be no less than six inches (6") or no more than twelve inches (12") measured from the end of the inlet pipe to the nearest point of the baffle. Outlet baffles shall be six inches (6") measured from beginning of the outlet pipe to the nearest point on the baffle.
- m. Access to the tank shall be as follows:
 - (1) Manholes. There shall be one (1) or more manholes. The manhole depth below finished grade shall extend to a point within eighteen inches (18") but no closer than eight inches (8") below finished grade. Manhole risers are not required when the top of the tank is within eighteen inches (18") of final grade. All manhole openings must be provided with a substantial, fitted, water-tight cover of concrete, cast iron, or other approved material. All manhole covers should be covered with at least six inches (6") of earth. Manhole covers which terminate above grade shall have an effective approved locking device if constructed of material other than concrete.
 - (2) There shall be an inspection access of at least six inches (6") diameter or a manhole over both the inlet and outlet devices. A downward projection of the center line of the inspection access shall be directly in line with the center line of the inlet or outlet device. It is not required to have an inspection pipe extended above grade. This access shall not be used for pumping.

- n. Compartmentation of single tanks shall be in accordance with the following:
- (1) Tanks larger than fifteen hundred (1,500) gallons and fabricated as a single unit shall be divided into two (2) or more compartments.
 - (2) When a tank is divided into three (3) or more compartments, one-half (1/2) of the total volume shall be in the first compartment and the other half equally divided in the other compartments.
 - (3) Connections between compartments shall be baffled so as to obtain effective retention of scum and sludge. The submergence of the inlet and outlet baffles of each compartment shall be as specified in Paragraphs II.G.2.g and h of this rule.
 - (4) Adequate venting shall be provided between compartments by baffles or by opening of at least fifty (50) square inches near the top of the compartment wall.
 - (5) Adequate access to each compartment shall be provided by one (1) or more manholes at least twenty inches (20") square or in diameter and located within six feet (6') of all walls of the tank.
- o. The use of multiple tanks shall conform with the following:
- (1) Where more than one (1) tank is used to obtain the required liquid volume, the tanks shall be connected in series.
 - (2) Each tank shall comply with all other provisions of this section.
 - (3) No more than three (3) tanks in series can be used to obtain the required liquid volume.
 - (4) The first tank shall be no smaller than any subsequent tanks in series.
- p. The liquid capacity of a tank serving a dwelling shall be based upon the number of bedrooms contemplated in the dwelling and shall be at least as large as the capacities given in Table IV: For six (6) or more bedrooms the tank shall be sized on the basis similar to an establishment. See Paragraph II. G.2.q of this section.

TABLE IV
Dwelling Tank Capacity

Number of Bedrooms	Minimum Liquid Capacity Gallons
1 to 3	1,000
4	1,250
5	1,500

Note: These figures provide for use of garbage grinders, automatic clothes washers and other household appliances.

- q. For individual residences with more than five (5) bedrooms, multiple-family residences or any place of business or public assembly, the liquid capacity of the tank shall be designed in accordance with the following:

Equation #1

$$V = 1.5Q + 500$$

Where V = is the liquid capacity of the tank.
Q = the design daily flow.

3. **Location.** Location of the tank shall include the following:
- The tank shall be placed so that it is accessible for the removal of liquids and accumulated solids.
 - The tank shall be placed on firm and settled soil capable of bearing the weight of the tank and its contents.
 - The tanks shall be set back as specified in **TABLE I** of this rule.
4. **Solids Removal.** The owner of any tank or his/her agent shall regularly inspect and arrange for the removal and sanitary disposal of septage from the tank whenever the top of the sludge layer is less than twelve inches (12") below the bottom of the outlet baffle or whenever the bottom of the scum layer is less than three inches (3") above the bottom of the outlet baffle. Yearly inspections of tanks are recommended. When a repair is made to any part of a wastewater treatment system, the tank shall be pumped and the baffles inspected.
5. **Pump Chambers.** Tanks for pumping effluent to a higher elevation (not for dosing) shall be a minimum volume equivalent to two (2) days flow. All chamber tanks must be concrete.

Example #1.

3 Bdr. home (360 gpd volume) = 1,000 gallon tank plus a 720 gallon liquid capacity pump chamber (to move the effluent).

6. **Aeration Units.** An aeration unit wastewater treatment plant utilizes the principle of oxidation in the decomposition of wastewater by the introduction of air into the wastewater. An aeration unit may be used as the primary treatment except where special local conditions may limit their use. All aeration unit type treatment systems shall comply with the general requirements for tanks set forth in **Subsection II.G.1** and with:
- Limitations.** Special conditions where aeration units should not be used may include, but not be limited to:
 - Where intermittent use will adversely affect the functioning of the plant.
 - Where local ordinances restrict their use.
 - General.** The aeration unit shall be located where it is readily accessible for inspection and maintenance. Set-back distances for aeration units shall be in accordance with **TABLE I** of these standards.
 - Design.** All aeration units shall comply with National Sanitation Foundation Standard No. 40 or as required by the health department. The aeration unit shall have a minimum treatment capacity of one thousand (1,000) gallons. In addition, all aeration unit treatment plants shall comply with the requirements stipulated in this section.
 - Effluent disposal.** Effluent from an aeration unit shall be discharged into a soil absorption system or other final treatment system in accordance with **Sections H and I** of these standards. No reductions in the area of soil absorption systems or other final treatment systems shall be permitted because of the use of an aeration unit. Direct surface discharge from an aeration unit treatment plant shall not be permitted.

- e. Operation and maintenance. Where aeration units are used, institutional or administrative arrangements to control their use, operation, and maintenance are recommended. Aeration units shall be pumped at least once a year to remove excess solids from the plant.
7. **Grease Traps.** Grease traps shall be required at food service facilities, meat markets, and other places of business where the accumulation of grease or oils can cause premature failure of a soil absorption system. The following design criteria shall be met:
- a. The grease trap shall be located as close to the fixtures being served as possible and shall be plumbed to receive all wastes associated with food handling but no toilet wastes.
 - b. The grease trap liquid capacity shall be sufficient to provide for at least five gallons (5 gals.) of storage per meal served per day or at least two-thirds ($2/3$) of the required tank liquid capacity.
 - c. Two (2) or more chambers must be provided, with total length-to-width ratio at least two to one (2:1). Chamber opening and outlet sanitary tee must extend down at least fifty percent (50%) of the liquid depth.
 - d. Access manholes with a minimum diameter of twenty-four inches (24"), shall be provided over each chamber and sanitary tee. The access manholes shall extend at least to finished grade and be designed and maintained to prevent surface water infiltration. The manholes shall also have readily removable covers to facilitate inspection and grease removal.
- H. **Absorption Systems.** The common design of absorption systems is one using absorption trenches, each separate from the other and each containing a distribution pipe. This type of system should be used whenever practical. Other types of absorption systems may be used as alternatives where the site conditions meet the specific design requirements of the advanced systems.

The amount of lateral lines needed can be figured by using the following calculation:

Equation #3

The number of bedrooms x 120 gallons per day (gpd) = flow rate
Flow rate divided by loading rate = square feet
Square feet divided by trench width = lineal feet

Example: 3 bedroom house
.5 loading rate (found on site evaluation form)
2 or 3 foot trench width

3 bedroom x 120 gpd = 360 gal. flow rate
360 gal. flow rate divided by .5 = 720 square feet
720 square feet divided by 3 feet = 240 lineal feet or
720 square feet divided by 2 feet = 360 lineal feet

1. **Absorption trenches.** An absorption trench gives additional treatment to the wastewater from the treatment tank. Regardless of its appearance of clarity or transparency, the outflow or effluent from a tank is a dangerous source of contamination. The satisfactory operation of the disposal system is largely dependent upon the proper site selection, design and construction of the absorption trench.
 - a. Absorption trenches shall not be constructed in soils with loading rates slower than 0.2 gpd/sq.ft. The maximum loading rate shall be 0.5 gpd/sq.ft. unless it is difficult to achieve this loading rate without modifications to the conventional trench.
 - b. The absorption trench shall be located on the property to maximize the vertical separation distance from the bottom of the absorption trench to the seasonal high ground water level, as determined by the presence of mottling, bedrock or other limiting layer. The vertical separation between the bottom of the absorption trench and limiting layer or seasonal high water table should be two feet (2') and in no case shall the separation distance be less than one foot (1') for standard systems.
 - c. Absorption trenches shall not be constructed in unstabilized fill or ground which has become severely compacted due to construction equipment.
 - d. Absorption trenches shall be constructed in soils which are dry.
 - e. Absorption trenches shall not be constructed in excavated soils, unless the soil scientist documents that the excavation will not interfere with treatment of the effluent.
 - f. Absorption trenches shall be constructed in undisturbed soils.
 - g. Curtain drains or approved vertical drains may be required where there is less than eighteen inches of separation between the trench bottom and the uppermost elevation of the seasonally high water table. Curtain drains shall be dug at least six inches (6") into the limiting layer and filled with gravel to the same depth as the perched water table. Curtain drains must be daylighted on at least one end, preferably on both ends. Screens shall cover the daylighted end of the pipe. Coiled tubing is not approved for use in the curtain drains. Perforated pipe of the same strength as laterals shall be placed in the bottom of the trench with the perforated hole pointed up towards the

- perched water table and away from the lateral field. Vertical drains shall not be used in areas where contamination may penetrate through the limiting layer. Vertical drains shall penetrate through the limiting layer. Both curtain drains and vertical drains may vary in width.
- h. Each absorption trench system shall have a minimum of two (2) trenches with no one (1) trench longer than one hundred feet (100'). The absorption trenches shall be located not less than three (3) times the trench width on centers with a minimum spacing of five feet (5') on centers.
 - i. Absorption trenches shall be at least eighteen inches (18") wide and no more than thirty-six inches (36") wide. The bottom of standard absorption trenches shall be at least eighteen inches (18") and not more than thirty inches (30") below the finished grade unless specifically approved otherwise.
 - j. The pipe used between the tank and the absorption system shall be a minimum of two feet (2') beyond the excavation for the tank and four inches (4") inside diameter and equivalent to the pipe used for the building sewer as set forth in these standards. The pipe shall have a minimum fall of not less than one-eighth inch (1/8") per foot. All joints shall be of watertight construction.
 - k. Gravity-fed absorption field distribution lines should be at least four inches (4") in diameter. Perforated distribution lines shall be used. The perforation shall be at least one-half inch (1/2") and no more than three-fourths inch (3/4") in diameter.
 - (1) All perforated pipe used in the absorption system shall meet ASTM Standard. ASTM Standard D-2729 has a minimum requirement for plastic pipe of 2,500 lb. crushproof. Perforated pipe with three (3) rows of holes shall **NOT** be used.
 - (2) **Coiled tubing shall not be used.**
 - l. The absorption trenches shall be constructed as level as possible but in no case shall the fall in a single trench bottom exceed one-fourth inch (1/4") in ten feet (10'). The ends of distribution lines shall be capped or plugged, or when they are at equal elevations, they should be connected. All caps shall be exposed for evaluation.
 - m. Rock used in soil absorption systems shall be clean, washed gravel or crushed stone and graded or sized between one to three inches (1" - 3") with no more than ten percent (10%) material to pass through a one-half inch (1/2") screen. Limestone, dolomite or other crushed rock shall be avoided when possible. If limestone, dolomite or other crushed rock is used, it shall be washed and be a minimum size of one and one-half inches (1 1/2 "). The rock shall be placed a minimum of one foot (1') deep with at least six inches (6") below the pipe and two inches (2") over the pipe and distributed uniformly across the trench bottom and over the pipe. Before placing soil backfill over the trenches, the gravel shall be covered with one of the following:
 - (1) Unbacked, rolled, three and one-half inch (3 1/2") thick fiberglass insulation.
 - (2) Untreated building paper.
 - (3) Synthetic drainage fabric.
 - (4) A minimum of eight inches (8") of straw for a compacted thickness of two inches.
 - (5) Other material approved by the health department laid as to separate the gravel from the backfill.

- n. Complex slope patterns and slopes dissected by gullies shall not be considered for installation of absorption trenches. Uniform slopes under fifteen percent (15%) shall be considered suitable for installation of absorption trenches. When slopes are less than two percent (2%), provisions shall be made to insure adequate surface drainage. When slopes are greater than four percent (4%), the absorption trenches shall follow the contour of the ground. Slopes greater than fifteen percent (15%) require installation of interceptor/curtain drains upslope from the soil absorption system to remove all excess water that might be moving laterally through the soil during wet periods. Usable areas larger than minimum are ordinarily required in this slope range. Slopes greater than thirty percent (30%) shall be considered unsuitable for installation of absorption trenches.
- o. Effluent distribution devices, including drop boxes, distribution boxes, flow dividers, and flow diversion devices, shall be of sound construction, watertight, not subject to excessive corrosion and of adequate design as approved by the health department. Effluent distribution devices shall be separated from the tank and absorption trenches by a minimum of two feet (2') of undisturbed or compacted soil and shall be placed level on a solid foundation of soil or concrete to prevent differential settlement of the device. Distribution boxes provided with flow equalizers are recommended.
- (1) Each distribution line shall connect individually to the distribution box and shall be water tight.
 - (2) The pipe connecting the distribution device to the distribution line shall be of a tight joint construction laid on undisturbed earth or properly bedded throughout its length.
 - (3) No more than four (4) distribution lines shall be connected to a distribution box receiving gravity flow.
- p. Stepdowns or drop boxes shall be used where topography prohibits the placement of absorption trenches on level grade. Whenever the design flow rate requires more than seven hundred fifty feet (750') of distribution line in a stepdown or drop box type system, the absorption field shall be divided into two (2) or more equal portions. Stepdowns shall be constructed of a minimum of two feet (2') of undisturbed soil and constructed to a height level with the top of the upper distribution line. The inlet to a trench relief line should be placed either in the center or as far as practical from the outlet (overflow) from the same trench. Drop boxes shall be constructed so that the inlet supply pipe is one inch (1") above the invert of the outlet supply pipe which is connected to the next lower drop box. The top of the trench outlet laterals, which allow effluent to move to the distribution lines, shall be two inches (2") below the invert of the outlet supply line. Drop boxes shall be designed to close off the trench outlets to provide for periods of resting if the absorption trench becomes saturated.
- q. Dosing is required for all systems when the design flow requires more than five hundred (500) lineal feet of distribution line. When the design flow requires more than one thousand (1,000) lineal feet of distribution line, the absorption field shall be divided into two (2) equal portions and each half dosed alternatively, not more than four (4) times per day. Dosing shall be accomplished by the use of a pump. Each side of the system shall be dosed not more than four (4) times per day. The volume of each dose shall be the greater of the daily volume divided by the daily dosing frequency or an amount to approximately three-fourths (3/4) of the internal volume of the distribution lines being dosed (approximately one-half (1/2) gallon per lineal foot of four-inch (4") pipe).

- r. The health department may permit the use of a bed system on sites where the minimum soil loading rate is 0.4 gpd/sq. ft. and essentially meeting the other requirements of this section, and only on lots which are limited by topography, space or other site planning considerations. In such cases the number of square feet of bottom area needed shall be increased by fifty percent (50%) over what would be required for a trench system. Distribution lines shall be at least eighteen inches (18") from the side of the bed and shall have lines on three-foot (3') centers. When the design volume of wastewater exceeds six hundred (600) gallons per day, adequate space shall be provided to accommodate a trench system for the absorption field. In any area where a bed system is proposed:
- (1) Elevation measurements of all four corners of the proposed bed must be included in the bed drawing.
 - (2) The bed will be limited to sites with two percent (2%) or less slope of the original grade.
 - (3) There will be no more than a two inch (2") change in total bed depth (floor grade) between the edges of the bed - (2 inches = 0.17 ft.).
 - (4) The lowest edge of the bed shall not be flush with the original grade.
 - (5) Sketch drawings for bed systems must include the following calculations:

Equation #4.

$$(100 \text{ Ft.} \div S) \times V = W$$

where S = Slope expressed in feet (elevation in 100 linear feet)

V = Maximum variation in bed depth (in feet)

W = Maximum width of bed

- s. Gravelless subsurface absorption systems may be used as an alternative. These systems include gravelless pipe and chamber systems that are installed under these conditions.
- (1) When replacing a conventional four-inch (4") pipe placed in gravel filled trenches.
 - (2) When the minimum soil-loading rate is 0.3 gpd/sq. ft.
 - (3) With a minimum of twelve inches (12") cover.
 - (4) With approval from the health department.
 - (5) Following all manufacturers specifications and installation procedures.
 - (6) Cannot be used in areas where conventional systems would not be allowed due to poor permeability, high groundwater, insufficient depth to bedrock, or a large amount of grease such as a restaurant.
- t. Modifications to standard absorption systems may be utilized to overcome selected soil and site limitations and must be approved by the health department include the following:
- (1) Shallow placement of absorption trenches shall be utilized where insufficient depth to seasonally high water table or limiting layer. Shallow trenches shall be designed and constructed to provide a minimum of twenty four inches (24") of natural soil separation between the trench bottom and the seasonally high water table or limiting layer. Shallow trenches shall be covered with loamy soil to a depth of eight to twelve inches (8-12") at center. The cover over the absorption field shall extend at least five feet (5') beyond the edge of any trench. Curtain or vertical drains are required when necessary to provide proper drainage.

- (2) Alternating dual field absorption systems may be utilized where soils are limited by high clogging potentials, a loading rate equal to or below 0.2 gpd/sq.ft. or high shrink/swell potential soils and where the potential for malfunction and need for immediate repair is required. Alternating dual field absorption systems shall be designed with two (2) complete absorption fields, each sized a minimum of seventy-five percent (75%) of the total area required for a single field and separated by an effluent flow diversion valve. The diversion valve shall be constructed to resist five hundred pounds (500 lbs.) crushing strength, structurally sound and shall be resistant to corrosion. Valves placed below ground level shall be installed so that it may be operated from the ground surface.
- (3) Sand-lined trenches may be used in areas where the soil has greater than fifty-percent (50%) rock fragments and there is an abnormally high potential for groundwater contamination. The material must be natural or manufactured sand and have no more than fifteen percent (15%) clay content. Clean river sand that is screened to one-fourth inch (1/4") and smaller may be used. Manufactured sand shall be chat sand produced from flint chat or fines manufactured from igneous rocks or chert gravel. **Crushed limestone is not acceptable.**
 - (a) In standard four-inch (4") pipe and gravel trenches the depth of liner material must be twelve inches (12") below the gravel and at least six inches (6") on the sides of the gravel up to the top of the gravel. To place sand on the sides of the trenches, the trench walls must be excavated on a slope instead of vertically. The side slopes should be two to one (2:1) and in no case steeper than one to one (1:1). When it is impossible to excavate the trenches on a slope the sand may be placed on the sides of trenches by digging the trench twelve inches (12") deeper than the recommended trench depth. The sand is placed eighteen inches (18") deep in the bottom of the trench and a V shaped form is dragged through the sand to push the sand at least six inches (6") up on the sides of the gravel.
 - (b) The effluent to sand-lined systems should be equally distributed as much as practically possible. Dosing is recommended in order to more positively assure even distribution.
 - (c) The sand-lined trenches may be used with the approval of the health department where the percentage of rock fragments is not greater than seventy percent (70%) for at least four feet (4') below the trench bottom. For sand-lined trenches to function properly, the permeability of the natural material should be similar to the permeability of the liner material. Sand-lined trenches must not be used over fragipans or other restrictive layers which have perched water tables and could cause saturation of the liner material.
 - (d) In gravelless pipe and chamber systems the minimum thickness of liner material is six inches (6") around the pipe.
- u. Wastewater Stabilization Ponds. A wastewater stabilization pond can provide satisfactory wastewater treatment in rural areas where soils are not suited for absorption systems. Single residence wastewater stabilization ponds are not generally suitable in subdivisions with lots less than three (3) acres in size. No more than one (1) single family residence will be allowed on one (1) stabilization pond.
 - (1) The minimum separation distances may be modified as necessary to accommodate the following site requirements:

- (a) The pond shall be located a minimum of seventy-five feet (75') from property lines as measured from the adjoining pond shoreline. However, this distance must be increased where necessary to be sure that all effluent is disposed upon the property from which it originated.
 - (b) The pond shall be located a minimum of two hundred feet (200') from the nearest existing residence and a minimum of one hundred feet (100') from the residence that it serves.
 - (c) The pond shall be located at least one hundred feet (100') from a potable water supply or pump suction line.
 - (d) The pond shall be located at least fifty feet (50') from a stream, water course, lake, or impoundment.
- (2) Ponds may be utilized when there are no significant limitations related to groundwater from their use and the soils have been demonstrated to be impermeable. There shall be a minimum separation distance between the pond bottom and creviced bedrock of three feet (3') or installation of a clay liner with a minimum thickness of one foot (1') or a synthetic liner. Percolation losses from the pond shall not exceed one-eighth inch (1/8") per day to prevent groundwater contamination or nuisance conditions. Site modifications may be accomplished to provide these soil requirements. In areas of highly permeable bedrock, restrictive layers such as fragipans shall be a minimum of twelve inches (12") thick and shall not be breached during construction.
 - (3) Steeply sloping areas should be avoided.
 - (4) Selection of the pond site should consider a clear sweep of the surrounding area by prevailing winds. Heavy timber should be removed for a distance of fifty feet (50') from the water's edge to enhance wind action and prevent shading.
 - (5) The health department requires that a properly sized and constructed tank precede the pond. The use of a tank should not be used as a basis for reduction of the setback distances as set forth in **paragraphs II H. 1. u (1) - (4)** of these standards.
 - (6) The pond shall be designed on the basis of four hundred forty (440) square feet of water surface area per bedroom at the three-foot (3') operating level. Whenever the pond is preceded by a properly sized tank, the water surface area may be reduced up to a maximum of twenty percent (20%); however, the minimum water surface area at the three foot (3') level shall be nine hundred (900) square feet.
 - (7) A single cell is generally acceptable for single residence pond systems. If multiple cells are used for further polishing or storage of the effluent, the secondary cell should be one-half (1/2) the size of the primary cell.
 - (8) The minimum embankment top width shall be four feet (4'). The embankment slopes shall not be steeper than three to one (3:1) on the inner and outer slopes. Outer embankment slopes shall be sufficient to prevent the entrance of surface water into the pond. Freeboard shall be at least eighteen inches (18") and preferably twenty-four inches (24"). Additional freeboard may be provided.
 - (9) Embankments shall be seeded with a locally hardy grass from the outside toe to one foot (1') above the water line to minimize erosion and facilitate weed control. Alfalfa or similar longrooted crops which might interfere with the water-holding capacity of the embankment shall not be used. Riprap may be necessary under unusual conditions to provide protection of embankments from erosion.

- (10) The influent line shall be of a sound, durable material of water-tight construction. The line shall have a minimum diameter of four (4) inches and be laid on a firm foundation at a minimum grade of one-fourth inch (1/4") per foot. The influent line shall discharge as far as practical from the possible outlet side of the pond. A cleanout or manhole should be provided in the influent line near the pond embankment. From this point the line should be laid to the inner toe of the embankment and then on the bottom of the pond to the terminus point. A concrete splash pad three feet (3') square should be placed under the terminus of the pipe. The elevation of the cleanout or manhole bottom should be a minimum of six inches (6") above the high water level in the pond.
- (11) The shape of the pond should be such that there are no narrow or elongated portions. Round, square, or rectangular cells are considered most desirable. Rectangular cells shall have a length not exceeding three (3) times the width. No islands, peninsulas, or coves shall be permitted. Embankments should be rounded at corners to minimize accumulation of floating materials.
- (12) The floor of the pond shall be stripped of vegetation and leveled to the proper elevation. Organic material removed from the pond area shall not be used in embankment construction. The wetted area of the pond must be sealed to prevent excessive exfiltration. Seals consisting of soils must be adequately compacted by the construction equipment or a sheeps-foot type roller may be used.
- (13) Embankments shall be constructed of impervious materials and compacted sufficiently to form a stable structure with very little settlement.
- (14) Any effluent should be withdrawn from six inches (6") below the water surface. This can be accomplished by placing the outlet pipe eight to ten inches (8-10") lower on the inlet end than the outlet end of the pipe.
- (15) The pond area shall be enclosed with a four-foot (4') high woven or chain-link fence to preclude livestock and discourage trespassing. The fence shall be so located to permit mowing of the embankment top and slopes. A gate of sufficient width to accommodate mowing equipment shall be provided. *The construction of this fence is the responsibility of the owner.*
- (16) Effluent from a pond must be disposed of on the property from which it originated. This may be accomplished by locating the outlet as far as practical from the property line and out of any natural drainage ditches or swales. The minimum distance from the outlet to a property line shall be one hundred feet (100'). Another method is to construct a terraced swale with a minimum length of one hundred fifty feet (150'). If these methods are unsuccessful, or whenever there is less than twelve inches (12") of permeable soil over a restrictive layer, controlled surface irrigation must be used. To utilize controlled surface irrigation, the pond must be capable of operating up to five feet (5') deep with one foot (1') of freeboard or have a second cell for storage. The health department shall approve the method of effluent disposal.
- (17) It may be necessary to introduce water into the pond to facilitate start-up of the biological processes, however, there shall be no permanent connection of any roof drain, footing drain or any source of rainwater to the wastewater stabilization pond.

- (18) Odor problems caused by spring turnover of water, temporary overloading, ice cover, atmospheric conditions or anaerobic conditions may be controlled by broadcasting sodium or ammonium nitrate over the surface of the pond. In general the amount of sodium or ammonium nitrate should not exceed two pounds (2 lbs.) per day until the odor dissipates.
- v. Holding Tanks. The use of holding tanks is generally discouraged and their interim use shall be limited to situations where construction of satisfactory wastewater treatment and disposal systems will occur within one (1) year. Use of a holding tank must be specifically approved by the health department. A Special Use Permit is required.
- (1) A holding tank shall be constructed of the materials and by the same procedures as those specified for watertight tanks.
 - (2) A cleanout pipe of at least six inches (6") diameter shall extend to the ground surface and be provided with a sealed and properly secured/locked lid. A manhole of at least twenty inches (20") dimension shall extend through the cover to a point within twelve inches (12") but no closer than six inches (6") below finished grade. The manhole cover shall be covered with at least six inches (6") of earth.
 - (3) The tank shall be protected against flotation under high water table conditions. This shall be achieved by weight of the tank, earth anchors, or shallow bury depths.
 - (4) For a residence, the size shall be one thousand gallons (1,000 gals.) or four hundred gallons (400 gals.) times the number of bedrooms, whichever is greater. For permanent structures other than residences, the capacity shall be based on measured flow rates or estimated flow rates. The tank capacity shall be at least five (5) times the daily flow rate.
 - (5) Holding tanks shall be located as follows:
 - (a) In an area readily accessible to the pump truck under all weather conditions;
 - (b) Set back distances as specified for tanks in **TABLE I** of these standards.
 - (c) Where accidental spillage during pumpage will not create a nuisance.
 - (6) A contract for disposal and treatment of the wastewater shall be maintained by the owner with a pumper, municipality, agency or firm which possesses a current and valid registration with the health department and a current and valid permit issued by the Missouri Department of Natural Resources for such activity. The owner shall keep records of who pumped the tank, when the tank was pumped, and where it was disposed. A copy of the contract shall accompany the application for permit.
 - (7) Holding tanks shall be monitored to minimize the chance of accidental sewage overflows. A high water alarm device shall be installed on all holding tanks so that it activates no higher than one foot (1') below the inlet pipe. This device shall be either an audible or illuminated alarm. If the latter is used, it shall be conspicuously mounted.
 - (8) Holding tanks used in conjunction with permanent black water/gray water systems must conform to the requirements of this section except that the minimum size tank is one thousand gallons (1,000 gals.). In these situations, the holding tank is to receive toilet wastes only.

- I. **Advanced Systems.** The health department requires that all advanced systems be designed and constructed by an installer registered specifically for advanced systems.
1. **General.** The intent of this section is to provide minimum standards for the design, location, installation, use and maintenance of advanced wastewater treatment systems in areas of limiting soil characteristics or where a standard system cannot be installed or is not the most suitable treatment.
 2. **Low Pressure Pipe.** The low pressure pipe system (LPP) is an advanced system that can be constructed in many areas where standard absorption trenches cannot. The LPP overcomes many problems with the site by utilizing uniform distribution of effluent, dosing and resting cycles and shallow placement of the trenches.
 3. **Wetlands.** The constructed wetland is an advanced system that provides secondary levels of treatment. This type of system requires some form of pretreatment such as a tank or a lagoon.
 4. **Elevated Sand Mounds.** The elevated sand mound is an advanced system that utilizes above ground soil absorption at the secondary level of treatment.
 5. **Sand Filter.** The sand filter, whether buried or recirculating, is an advanced system that provides secondary levels of treatment in tight soils.
 6. **Other Systems.** Where unusual conditions exist, special systems of treatment and disposal, other than those specifically mentioned in these standards, may be employed provided:
 - a. Reasonable assurance of performance of the system is presented to the health department. Specific technical data, not personal opinions or sales literature, is to be submitted to this department. An opinion from an engineer, soil scientist, geologist regarding the system without specific technical data will not be considered for approval.
 - b. The engineering design of the system is first approved by the health department. The report will specifically detail how no other system mentioned in these standards can successfully be employed on this site.
 - c. There is no discharge to the ground surface or surface waters.
 - d. Adequate substantiating data to indicate that the effluent will not contaminate any drinking water supply, groundwater used for drinking water, or any surface water.
 - e. Treatment and disposal of the wastes protects public health and general welfare.
 - f. These systems comply with all applicable requirements of these standards and with all applicable requirements of the Missouri statutes.
 - g. Specific construction criteria for these systems are not provided in these standards, therefore there will be a statement on the construction permit that this is an experimental system.

III. SOIL EVALUATION

- A. General.** The intent of this section is to provide minimum standards for site evaluations based upon evaluation of the soil characteristics, namely texture, color, structure, drainage and depth. Criteria are also given for sizing standard systems and some advanced systems. This type of evaluation shall be conducted by a professional soil scientist, engineer, environmental public health specialist or registered geologist with special training in determining soil morphological characteristics in the field. The person performing the site evaluation shall be registered in Newton County.
- B. Site Evaluation.** An investigation of a proposed soil absorption site shall consider the following factors:
1. Topography and landscape position;
 2. Soil characteristics (morphology) which includes texture, structure, porosity, consistence, color and other physical, mineral and biological properties of various horizons in the soil profile;
 3. Soil drainage, which includes both external (surface) and internal (soil);
 4. Soil depth;
 5. Restrictive horizons; and
 6. Available space.
- C. Site Evaluation Classification.** Site evaluations shall be made in accordance with these standards. Based on this evaluation, each of the factors listed shall be classified as Suitable (S), Provisionally Suitable (PS), or Unsuitable (U).
- D. Topography and Landscape Position.** Uniform slopes under fifteen percent (15%) shall be considered suitable with respect to topography. When slopes are less than two percent (2%), provisions shall be made to insure adequate surface drainage. When slopes are greater than four percent (4%), the absorption lines shall follow the contour of the ground.
1. Uniform slopes of fifteen percent (15%) through thirty percent (30%) shall be considered provisionally suitable with respect to topography, (except for highly permeable soils). Slopes within this range may require installation of interceptor drains upslope from the soil absorption system to remove all excess water that might be moving laterally through the soil during wet periods. Usable areas larger than minimum are ordinarily required in this slope range.
 2. Slopes greater than thirty percent (30%) shall be considered unsuitable.
 3. Complex slope patterns and slopes dissected by gullies and ravines shall be considered unsuitable topography.
 4. Areas subject to frequent flooding shall be considered unsuitable to landscape positions.
 5. Depressions shall be considered unsuitable with respect to landscape positions except when the site complies essentially with the requirements of this section and is specifically approved by the health department.

6. The surface area on or around a ground absorption treatment and disposal system shall be landscaped to provide adequate drainage. The interception of perched or lateral groundwater movement shall be provided where necessary to prevent soil saturation on or around the ground absorption treatment and disposal system.

E. Soil Characteristics (Morphology):

1. Texture. The relative amounts of the different sizes of mineral particles in a soil are referred to as soil texture. All mineral soils are composed of sand, two to five hundredths millimeter (2-.05 mm) in size; silt, which includes intermediate-sized particles that cannot be seen with the naked eye but feel like flour when pressed between the fingers, five hundredths to two thousandths millimeter (0.05-0.002 mm) in size, that gives cohesion to a soil less than two thousandths millimeter (0.002 mm) in size or a combination of these. The texture of the different horizons of soils may be classified into five (5) general groups and shall be used for determining the application rates.
 - a. Soil Group I. Sandy texture soils contain more than seventy percent (70%) sand-sized particles in the soil mass. These soils do not have enough clay to be cohesive. Sandy soils have favorable wastewater application rates, but may have a low filtering capacity leading to malfunction due to contamination of groundwater. The sandy group includes the sand and loamy sand soil textural classes and shall generally be considered suitable in texture.
 - (1) Sand. Sand has a gritty feel, does not stain the fingers and does not form a ribbon or ball when wet or moist.
 - (2) Loamy sand. Loamy sand has a gritty feel, stains the fingers (silt and clay), forms a weak ball and cannot be handled without breaking.
 - b. Soil Group II. Coarse loamy texture soils contain more than thirty percent (30%) sand-sized particles and less than twenty percent (20%) clay-sized particles in the soil mass. They exhibit slight or no stickiness. The coarse loamy group includes sandy loam and loam soil textural classes and shall generally be considered suitable in texture.
 - (1) Sandy loam. Sandy loam feels gritty and forms a ball that can be picked up with the fingers and handled with care without breaking.
 - (2) Loam. Loam may feel slightly gritty but does not show a fingerprint and forms only short ribbons ranging from twenty-five hundredths to fifty hundredths inch (.25-.50") in length. Loam will form a ball that can be handled without breaking.
 - c. Soil Group III. These fine loamy texture soils contain less than thirty-five percent (35%) clay-sized particles and not more than thirty percent (30%) sand-sized particles in a soil mass. They exhibit slight to moderate stickiness. The fine loamy group includes sandy clay loam, silt loam, clay loam and silty clay loam textural classes and shall generally be considered provisionally suitable in texture.
 - (1) Silt loam. Silt loam feels floury when moist and will show a fingerprint but will not ribbon and forms only a weak ball.
 - (2) Silt. Silt has a floury feel when moist and sticky when wet, but will not ribbon and forms a ball that will tolerate some handling.

- (3) Sandy clay loam. Sandy clay loam feels gritty but contains enough clay to form a firm ball and may ribbon to form seventy-five hundredths to one-inch (.75-1") pieces.
 - (4) Silty clay loam. Silty clay loam is sticky when moist and will ribbon from one to two inches (1-2"). Rubbing silty clay loam with the thumbnail produces a moderate sheen. Silty clay loam produces a distinct fingerprint.
 - (5) Clay loam. Clay loam is sticky when moist. Clay loam forms a thin ribbon of one to two inches (1-2") in length and produces a slight sheen when rubbed with the thumbnail. Clay loam produces a nondistinct fingerprint.
- d. Soil Group IV. These clayey texture soils contain forty percent (40%) or more clay-sized particles and include sandy clay, silty clay, and clay. This group may also include clay loam and silty clay loam when the clay fraction is thirty-five percent (35%). For evaluation purposes, 'clayey soil' will indicate thirty-five percent (35%) or greater clay content. There are two (2) major types of clays - non-expandable and expandable. The non-expandable clays, when wet, are slightly sticky to sticky; when moist, are friable to firm; and when dry, they are slightly hard to hard. The non-expandable clays, (Group IVa) shall generally be considered provisionally suitable in texture. The expandable clays, when wet, are very sticky and very plastic and when moist these clays are very firm to extremely firm and when dry are very hard to extremely hard. The expandable clays (Group IVb) shall be considered unsuitable in texture. Soil group IVb may include soils with thirty-five percent (35%) or greater gravel content. If soil horizons in soil group IV are anticipated to have unsuitable permeability, or if permeability is due primarily to the gravel content, (i.e. fine earth fraction has unsuitable permeability), these horizons will be placed in soil group IVb regardless of the perceived type of clay.
- (1) Sandy clay. Sandy clay is plastic, gritty and sticky when moist and forms a firm ball and produces a thin ribbon to over two (2) inches in length.
 - (2) Silty clay. Silty clay is both plastic and sticky when moist and lacks any gritty feeling. Silty clay forms a firm ball and readily ribbons to over two inches (2") in length.
 - (3) Clay. Clay is both sticky and plastic when moist, produces a thin ribbon over two inches (2") in length, produces a high sheen when rubbed with the thumbnail and forms a strong ball resistant to breaking.
- e. Soil Group V. This soil group may be of any texture, however, the most predominant are cherty and very cherty clays, silt loams and silty clay loams. The amount of rock fragments in these soils is of a concern in areas of residual soils overlying highly permeable bedrock where ground water could become contaminated. Soils with fifty percent (50%) or less rock fragments will be considered suitable. Soils of fifty percent (50%) through seventy percent (70%) rock fragments will be considered provisionally suitable. Soils with greater than seventy percent (70%) rock fragments will be considered unsuitable.
- f. The soil texture shall be estimated by field testing.

2. Soil consistence. Soil consistence comprises the attributes of soil material, typically clay, that are expressed by the degree and kind of cohesion and adhesion or by the resistance to deformation or rupture. Soil consistence shall be reported for soil horizons with thirty-five percent (35%) or greater clay content using wet conditions.

- a. Soil consistence when wet shall be considered as follows:
- (1) Stickiness. Stickiness is the quality of adhesion to other objects. For field evaluation of stickiness, wet soil material is pressed between thumb and finger and its adherence noted. Degrees of stickiness are described as follows:
 - (a) Slightly sticky. After pressure, soil material adheres to both thumb and finger but comes off one or the other cleanly. It is not appreciably stretched when the digits are separated.
 - (b) Sticky. After pressure, soil material adheres to both thumb and finger and tends to stretch somewhat and pull apart rather than pulling free from either digit.
 - (c) Very sticky. After pressure, soil material adheres to both thumb and finger and is decidedly stretched when they are separated.
 - (2) Plasticity. Plasticity is the ability to change shape continuously under the influence of an applied stress and to retain the impressed shape on removal of the stress. For field determination of plasticity, roll the soil material between the thumb and finger and observe whether or not a wire or thin rod of soil can be formed. Degree of resistance to deformation at or slightly above field capacity is as follows:
 - (a) Slightly plastic. Wire formable but soil mass easily deformable.
 - (b) Plastic. Wire formable and moderate pressure required for deformation of the soil mass.
 - (c) Very plastic. Wire formable and much pressure required for deformation of the soil mass.
- b. Soil consistence when moist. Consistence when moist is determined at a moisture content approximately midway between air dry and field capacity. At this moisture content, most soil materials exhibit a form of consistence characterized by: tendency to break into smaller masses rather than into powder; some deformation prior to rupture; absence of brittleness; and ability of the material after disturbance to cohere again when pressed together. To evaluate this consistence, select and attempt to crush in the hand a mass that appears slightly moist.
- (1) Friable. Soil material crushes easily under gentle to moderate pressure between thumb and finger, and coheres when pressed together.
 - (2) Firm. Soil material crushes under moderate pressure between thumb and finger but resistance is distinctly noticeable.
 - (3) Very firm. Soil material crushes under strong pressure; barely crushable between thumb and finger.
 - (4) Extremely firm. Soil material crushes only under very strong pressure; cannot be crushed between thumb and finger and must be broken apart bit by bit.
- c. Soil consistency when dry. The consistency of soil materials when dry is characterized by rigidity, brittleness, maximum resistance to pressure, more or less tendency to crush to a powder or to fragments with rather sharp edges, and inability of crushed material to cohere again when pressed together. For evaluation, the air-dry mass shall be selected and broken in the hand.
- (1) Slightly hard. Weakly resistant to pressure; easily broken between thumb and finger.
 - (2) Hard. Moderately resistant to pressure; can be broken in the hands without difficulty but is barely breakable between thumb and finger.

(3) Very hard. Very resistant to pressure; can be broken in the hands only with difficulty; not breakable between thumb and finger.

(4) Extremely hard. Extremely resistant to pressure; cannot be broken in the hands.

3. Organic soils. Organic soils shall be considered unsuitable.

4. Soil structure. In many soils, the sand, silt, and clay particles tend to cling or stick to one another to form a ped or a clump of soil. This is known as soil structure. Soil structure may have a significant effect on the movement of effluent through a soil. Structure is usually not important in soil groups I and II, and these types of soils shall generally be considered suitable as to structure. The three (3) kinds of soil structure that are most significant in movement of effluent through groups III and IV soils are block-like, platy and the absence of soil structure or massive conditions. These kinds of soil structure are described as follows:

- a. Block-like soil structure. In group III and IV soils, if the soil exhibits many peds of angular and subangular peds, then the soils have block-like structure. The effluent may move between the cracks of these types of peds. Block-like structure in group III and IV soils is frequently destroyed by mechanical excavating equipment manipulating the soil when it is too wet. Trenches for absorption lines being placed in group III and IV soils with block-like structure should only be dug when the soils are moist or dry. Block-like soil structure in Groups III and IV soils shall be considered provisionally suitable.
- b. Platy soil structure. If group III and IV soils fall out into plate-like sheets, then the soil would have platy structure. Water or effluent movement through these soils would be extremely slow, and the structure shall be considered unsuitable.
- c. Absence of soil structure. Some group II, III and IV soils are massive and exhibit no structural aggregates. In these kinds of soils, water or effluent movement would be negligible. This structure shall be considered unsuitable.

F. **Soil Drainage**. Soils with seasonally high water tables are of major concern in evaluating sites for wastewater disposal. These are the soil areas that give good absorption rates during dry seasons of the year but force effluent to the surface during the wetter seasons.

1. The depth of the seasonal high water table can commonly be recognized by those examining soil profiles. The criteria for recognition of high water tables is that of soil color. Subsurface horizons that are in colors of reds, yellows, and browns generally indicate good soil aeration and drainage throughout the year. Subsurface horizons that are in colors of gray, olive, or bluish colors, of chroma 2 or less (Munsell Color Chart) indicate poor aeration and poor soil drainage. These dull or grayish colors may occur as a solid mass of soil or may be in mottles of localized spots. The volume of grayish color is indicative of the length of time that free water stands in that soil profile. There are soils that have light-colored mottles which are relic from the light-colored rock from which the soils have weathered. These soils would not have high water tables, so one must distinguish between a true soil composed of sand, silts, and clays, or the rock material that may still exist in the soil profile.

2. Any soil horizon that has the grayish colors of chroma 2 or less (Munsell Color Chart) indicative of high water tables shall be considered unsuitable as to drainage.
- G. Soil Thickness.** Soil thickness will represent the depth to bedrock or paralithic (soft bedrock) contact. Soil depth suitability classifications shall be as follows:
1. Soil depths of forty-eight inches (48") or greater shall be considered suitable.
 2. Soil depths less than forty-eight inches (48") but that are thirty-six inches (36") or greater shall be considered provisionally suitable.
 3. There shall be a minimum of two feet (2') separation distance between the bottom of the absorption trench and bedrock.
- H. Restrictive Horizons.** Restrictive horizons severely restrict the movement of water and air and shall be considered unsuitable. These restrictive horizons shall not be breached. Restrictive horizons in soils are recognized by their apparent resistance in excavation or in using a soil auger. Restrictive horizons may occur as fragipans or claypans. The fragipan is a layer that owes its hardness mainly to extreme density or compactness as opposed to high clay content or cementation. The layer is typically dense and brittle. Although fragments are friable when removed, when in place the material is so dense water moves through it very slowly. Unlike fragipans, the claypan is a compact, slowly permeable layer in the subsoil having a much higher clay content than the overlying material. A sharply defined boundary exists between the claypan and the overlying material. Claypans are typically hard when dry and plastic and sticky when wet.
- I. Other Applicable Factors.** The site evaluation should include consideration of any other applicable factors involving environmental principles including:
1. The proximity of a large capacity water supply well, the cone of influence of which would dictate a larger separation distance than the minimum specified in these standards.
 2. The potential environmental hazard of possible failures of soil absorption systems involving large quantities of wastewater, which would dictate larger separation distances than the minimums specified in these standards.
 3. The potential environmental and health hazard of possible massive failures of soil absorption systems proposed to serve large numbers of residences, as in residential subdivisions or mobile home parks.
- J. Determination of Overall Site Suitability Classification.** This is the classification reported on the site evaluation form representing a specific factor to determine the overall site suitability for subsurface soil absorption systems. The representative suitability classification for a soil factor is determined by the soil factor in relation to the entire soil and the minimum criteria for a conventional or alternative wastewater system. The lowest representative suitability classification of the individual site factors will determine the overall site suitability classification.
1. Suitable Classification. Site factors that meet the minimum criteria, without any required provisions, for a standard absorption system at the maximum allowable trench depth shall be classified suitable.

2. Provisionally Suitable Classification. Site factors that with required provisions meet the minimum criteria for a system specified in the standards shall be classified provisionally suitable.
 3. Unsuitable Classification. Where it is anticipated that the severe limitations cannot be mitigated, then the site shall be considered unsuitable. The site evaluator shall state on the soil evaluation form that the site is unsuitable if he or she believes the limitations will clearly create an unacceptably high potential for system failure.
- K. Design Criteria.** Tables V and VI may be used when determining the application rate for the appropriate system.

TABLE V
APPLICATION RATES BY SOIL GROUP FOR CONVENTIONAL SYSTEMS

SOIL GROUP	SOIL TEXTURE	CLASSES	APPLICATION RATE gpd/sq. ft. (conventional)
1	Sand, Loamy sand	Any striation/brown (no gray)	1.2 - 0.8
2	Sandy loam, Loam	Granular, fine and medium subangular blocky. Prismatic, coarse sub- angular and angular blocky.	0.9 - 0.7 0.7 - 0.5
3	Silt loam, Clay loam, Sandy clay loam, Silty clay loam ($<35\%$ clay)	Granular, fine and medium subangular blocky. Prismatic, coarse sub- angular and angular blocky.	0.6 - 0.4 0.4 - 0.3
4a	Sandy clay, Silty clay, ($\geq 35\%$ clay), Clay (low to moderate shrink/swell)	Granular, fine and medium subangular blocky. Prismatic, coarse sub- angular and angular blocky.	0.4 - 0.2 0.3 - 0.1
4b	Sandy clay, Clay, Silty clay loam, Silty clay (high shrink/swell potential) ($\geq 35\%$ clay)	Subangular, angular blocky, or prismatic.	Unsuitable
5	Skeletal (less than 50% coarse frag- ments), Silt loam Silty clay loam, Clay, Silty clay	Anything but platy or massive.	0.4 - 0.2

TABLE VI
APPLICATION RATES BY SOIL GROUP

SOIL GROUP	SOIL TEXTURE	CLASSES	APPLICATION RATE gpd/sq. ft. (Low Pressure Pipe)
1	Sand, Loamy sand	Any striation/brown (no gray)	0.5 - 0.4
2	Sandy loam, Loam	Granular, fine and medium subangular blocky. Prismatic, coarse sub- angular and angular blocky.	0.4 - 0.35 0.3 - 0.2
3	Silt loam, Clay loam, Sandy clay loam, Silty clay loam ($< 35\%$ clay)	Granular, fine and medium subangular blocky. Prismatic, coarse sub- and angular blocky.	0.3 - 0.2 0.20 - 0.15
4a	Sandy clay, Silty clay, ($\geq 35\%$ clay), Clay (low to moderate shrink/swell)	Granular, fine and medium subangular blocky. Prismatic, coarse sub- angular and angular blocky.	0.2 - 0.1 0.1 - 0.05
4b	Sandy clay, Clay loam, Clay, Silty clay loam, Silty clay (high shrink/swell) ($\geq 35\%$ clay)	Subangular, angular blocky, or prismatic	Unsuitable
5	Skeletal (less than 50% coarse frag- ments), Silt loam Silty clay loam, Clay, Silty clay	Anything but platy or massive	0.3 - 0.15

APPENDIX A

FORMS

Attachment A
 Newton County Health Department
 Environmental Fee Schedule
 (Revised 2021)

Service	Fee Schedule
Single Family Dwelling Septic Permit	\$150.00
Non-Single Family Dwelling Septic Permit	\$225.00
Repair Septic	\$30.00
Official Bacteria Water Sample (Health Dept. Collecting)	\$30.00
Nitrate	\$15.00
Unofficial Bacteria Water Sample (Individual Collecting)	\$25.00
Nitrate	\$10.00
Lead/Cadmium/Zinc (Health Dept. Collecting)	\$30.00
Tattoo Permit (Annual Fee)	\$100.00
High risk food establishment (Annual Fee)	\$250.00
Medium risk food establishment (Annual Fee)	\$175.00
Low risk food establishment (Annual Fee)	\$100.00
Mobile food unit (Annual Fee)	\$100.00
Temporary event food stand (Fee per event)	\$25.00/Event
Septic System General Installer Registration (Annual Fee)	\$30.00
Septic System Advanced Installer Registration (Annual Fee)	\$40.00
Septic Tank Cleaner Registration (Annual Fee)	\$30.00
Soil Scientist Registration (Annual Fee)	\$30.00

PART ONE .

PERMIT TO REPAIR NO. _____

LOAN _____ GRANT _____ COMPLAINT _____

FOR REPLACEMENT PARTS ONLY.

REPAIR PERMIT for a Wastewater Treatment System

Return completed form, copy of site evaluation and appropriate fee to:

Newton County Health Department

P.O. Box 447, Neosho, MO 64850

Applicant Complete This Section

Owner's Name: _____ Daytime Phone No.: _____

E911 Address of Property: _____

Mailing Address: _____

Legal Description of Property: _____ 1/4 _____ 1/4, S _____ T _____ R _____

PROPERTY - Directions to site (include street names): _____

TYPE OF OCCUPANCY:

Residence: Number of bedrooms _____ Number of persons in home _____

Commercial: Type _____ Number of persons or employees served _____

Is the property located in a subdivision regulated by Missouri Department of Natural Resources:

YES _____ NO _____ Lot Number _____ A copy of MODNR's approval for the subdivision will be needed.

Describe the REPAIR _____

I certify that to the best of my knowledge the information contained on this form is correct and the proposed work will be completed in accordance with the permit issued.

Owner/Representative

Name and Signature: _____ Date _____

Installer Name and Signature: _____ Date _____

Installer Daytime Phone No.: _____

TO BE COMPLETED BY THE INSTALLER ONLY.

PROPOSED REPAIR PLAN

DRAWN BY: _____ **FOR:** _____

INSTALLER'S NAME

HOMEOWNER'S NAME

MUST INDICATE THE DIRECTION NORTH

LOT DIMENSIONS: _____ **LENGTH** _____ **WIDTH OR NUMBER OF ACRES** _____

DESIGN DETAILS (FILL IN THE BLANKS)

_____ FT OF 4" SCD 40 BETWEEN HOUSE AND TANK

_____ FT OF 4" SCD 40 PAST EXCAVATION HOLE

_____ GALLON CONCRETE TANK

_____ MANUFACTURER OF TANK

_____ % OF SLOPE OF GROUND IN THE
LATERAL FIELD AREA

_____ FT. SETBACK TO PROPERTY LINE

_____ FT. SETBACK TO ALL WELLS IN AREA

_____ SERVICE CONNECTIONS TO WELL
(NUMBER OF BUILDINGS USING WELL)

INDICATE IF AN ADVANCED SYSTEM IS BEING REPAIRED:

_____ " DEPTH OF TRENCH

_____ " WIDTH OF TRENCH

_____ TYPE OF BARRIER MATERIAL

_____ " LATERAL ROCK ON TOP OF PIPE

_____ 4" OF CLEAN ROCK AROUND PIPE

_____ " OF LATERAL ROCK UNDER PIPE

PART ONE

PERMIT TO INSTALL NO. _____

LOAN ___ GRANT ___ COMPLAINT ___

PERMIT APPLICATION for a Wastewater Treatment System

Return completed form, copy of site evaluation and appropriate fee to:

Newton County Health Department

P.O. Box 447, Neosho, MO 64850

Applicant Complete This Section

Owner's Name: _____ Daytime Phone No.: _____

E911 Address of Property: _____

Mailing Address: _____ City State Zip

Legal Description of Property: _____ 1/4 _____ 1/4, S _____ T _____ R _____ City State Zip

PROPERTY - Directions to site (include street names): _____

TYPE OF OCCUPANCY

Residence: Number of bedrooms _____ Number of persons in home _____

Commercial: Type _____ Number of persons or employees served _____

Is the property located in a subdivision regulated by Missouri Department of Natural Resources:

YES ___ NO ___ Lot Number _____ A copy of MODNR's approval for the subdivision will be needed
Subdivision name: _____

I certify that to the best of my knowledge the information contained on this form is correct and the proposed work will be completed in accordance with the permit issued.

Owner/Representative
Name and Signature: _____ Date _____

Installer Name and signature: _____ Date _____

Installer Daytime Phone No.: _____

APPENDIX B

DRAWINGS

CURTAIN DRAINS

Curtain drains intercept laterally moving perched water tables caused by a shallow, impermeable restrictive horizon. Curtain drains are placed a minimum of six inches (6") into the top of the restrictive horizon and filled with gravel to the same depth as the perched water table. Perforated pipe (not coiled tubing) is placed in the bottom of the trench with the holes pointed up toward the perched water table and away from the lateral field. If the site has sufficient slope, the drains are brought to the surface downslope to allow free drainage and the ends are screened. On level sites, pumps must be used to remove the collected water.

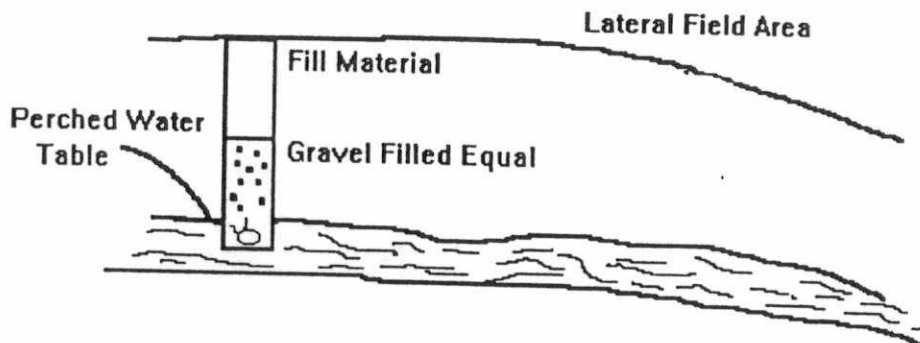

VERTICAL DRAINS

If the restrictive layer is thin and overlies permeable soil, vertical drains may be used. The trench is excavated through the restrictive layer into the more permeable soil below and backfilled with porous material.

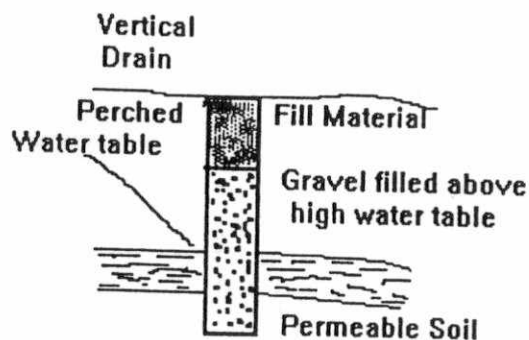

SAND-LINED TRENCHES

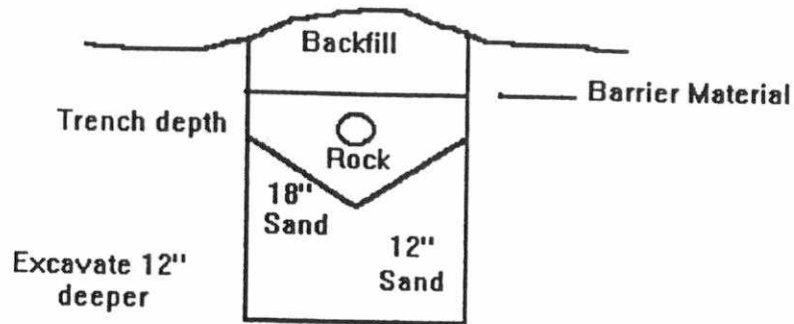

EXAMPLE: SHALLOW PLACEMENT

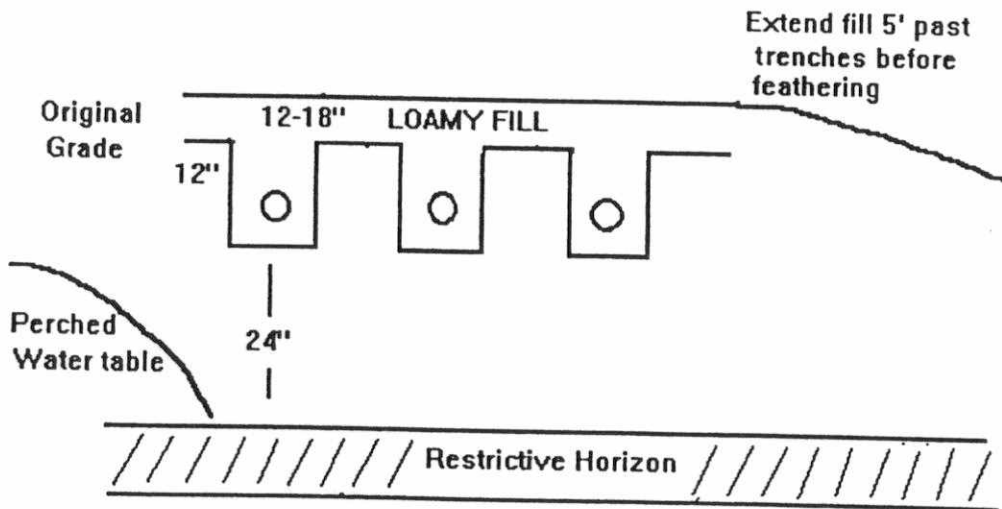

EXAMPLES: STEP-DOWN SYSTEMS

Laterals must follow contours

slope

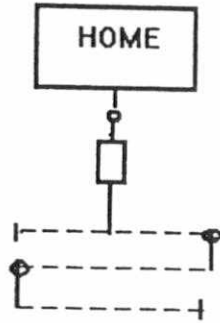

step-down
*see details below

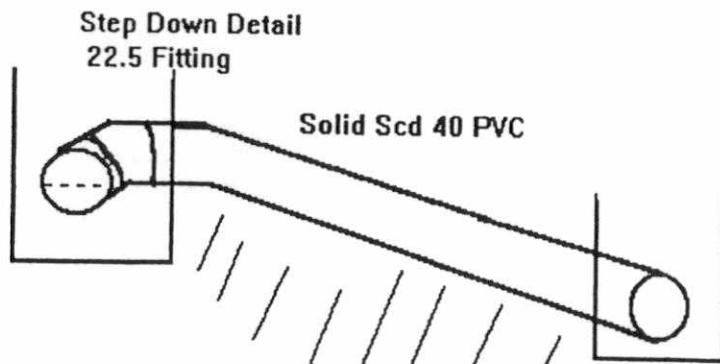
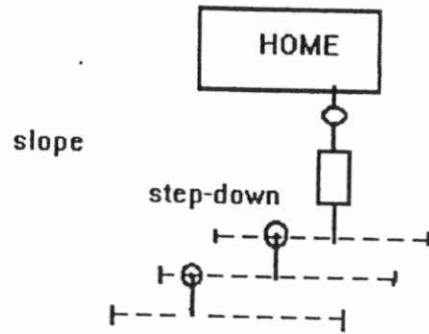
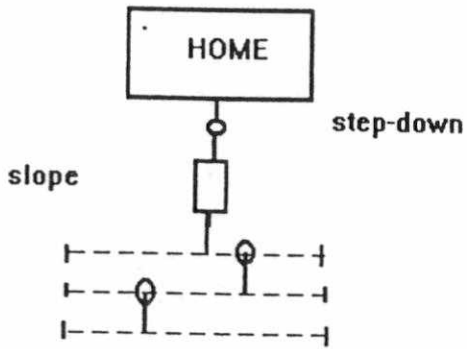

Earth dam - pipe and fitting must be installed so that 4" lateral pipe is 1/2 full before overflow in stepdown occurs.

EXAMPLE: LEVEL SYSTEM

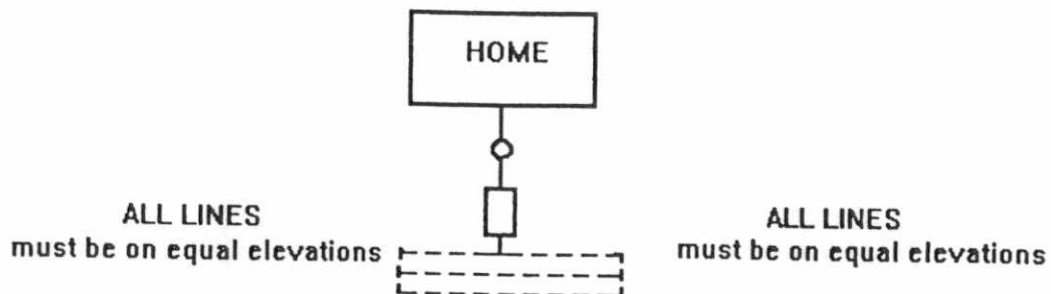

"Level" topography systems are to be used ONLY when the distribution lines are at equal elevations. When "level systems are used, the ends of the distribution lines are to be connected with perforated 4" PVC of the appropriate strength.

TRENCHES

EXAMPLE: CONVENTIONAL TRENCH

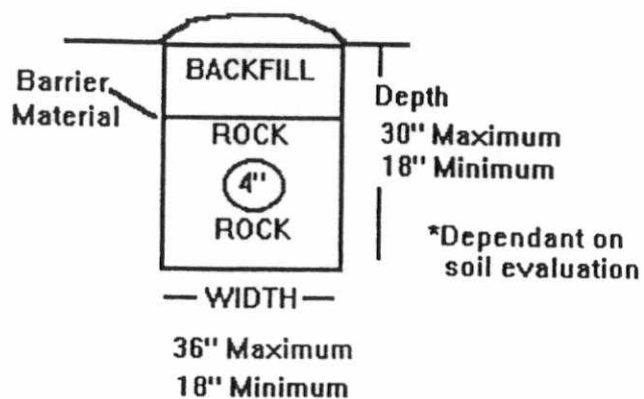

DROP BOX SYSTEMS

